

INCH-POUND

MS28773A
22 December 2005
Superseding
MS28773
4 November 1966

DETAIL SPECIFICATION

RETAINER, PACKING, BACK-UP, TETRAFLUOROETHYLENE, STRAIGHT
THREAD TUBE FITTING BOSS

Inactive for new design after 5 September 1997.

This specification sheet is approved for use by all Departments and Agencies of the Department of Defense.

The requirements for acquiring the product described herein shall consist of this specification sheet and SAE-AS8791.

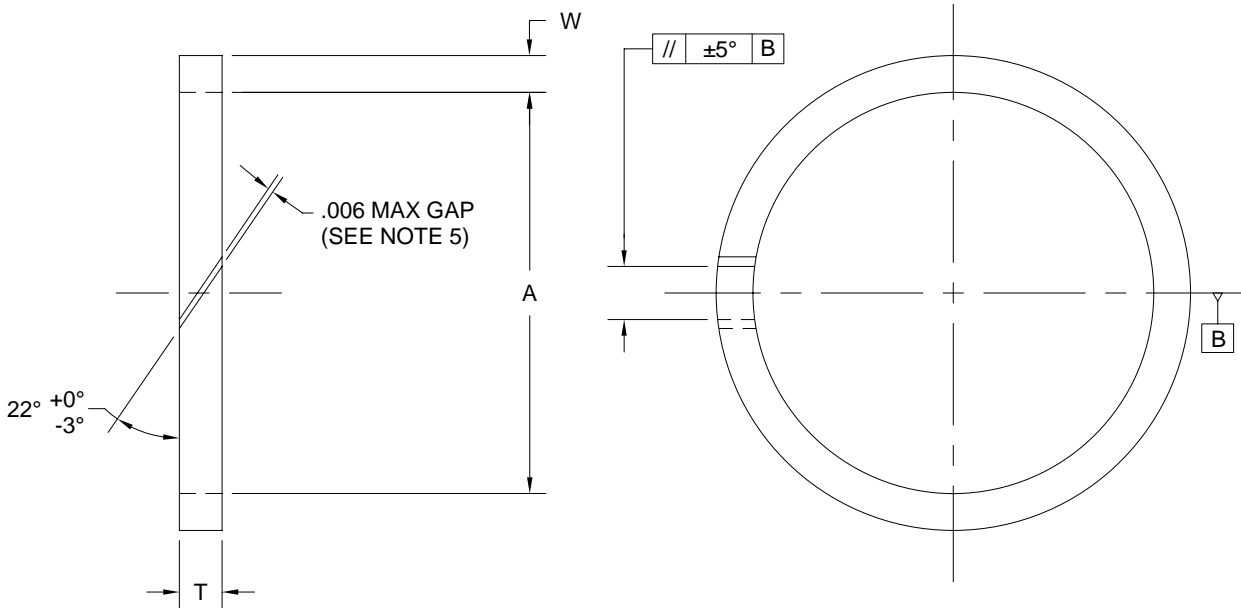

FIGURE 1

MS28773A

Table I. Dash numbers and dimensions.

DASH NO.	NOM TUBE O.D.	A BASIC	W ±.001	T ±.001	APPROX WEIGHT LB/100
-02	.125 (1/8)	.246	.112	.056	.056
-03	.187 (3/16)	.309	.112	.056	.066
-04	.250 (1/4)	.360	.117	.061	.085
-05	.312 (5/16)	.423	.117	.061	.096
-06	.375 (3/8)	.478	.121	.061	.110
-08	.500 (1/2)	.656	.125	.061	.149
-10	.625 (5/8)	.769	.131	.073	.216
-12	.750 (3/4)	.941	.169	.073	.342
-16	1.000 (1)	1.191	.169	.073	.419
-20	1.250 (1-1/4)	1.503	.169	.073	.515
-24	1.500 (1-1/2)	1.752	.169	.073	.592
-28	1.750 (1-3/4)	2.127	.169	.073	.707
-32	2.000 (2)	2.377	.169	.073	.784

NOTES:

1. Material: SAE-AS8791.
2. Surfaces must be smooth and free from irregularities. Edges must be clean and sharp.
3. Dimensions in inches.
4. Dash numbers correspond to the equivalent dash numbers of the SAE-AS28778 preformed packings and the SAE-AS5179 nut.
Example: MS28773-04 retainer to be used with part numbers MS28778-4 packing and AS5179-4 nut.
5. This dimension to be met with retainer mounted on a mandrel of "A" diameter.
6. For design feature purposes, this standard takes precedence over documents referenced herein.
7. Referenced documents shall be of the issue in effect on the date of invitations for bid.
8. Changes from previous issue. Marginal notations are not used in this revision to identify changes with respect to the previous issue due to the extent of the changes.

Custodians:
Army - AV
Navy - AS
Air Force - 99

Preparing activity:
DLA - IS

(Project 5330-2005-004)

Reviewer activities:
Army - MI
Air Force - 71

NOTE: The activities listed above were interested in this document as of the date of this document. Since organizations and responsibilities can change, you should verify the currency of the information above using the ASSIST Online database at <http://assist.daps.dla.mil>.