

REQUIREMENTS FOR ACQUIRING THE PRODUCT(S) DESCRIBED HEREIN SHALL CONSIST OF  
 SHEET AND THE ISSUE OF THE FOLLOWING SPECIFICATION LISTED IN THAT ISSUE OF THE DOD  
 THE SOLICITATION MIL-F-10884

THIS SPECIFICATION IS APPROVED FOR USE BY ALL DEPARTMENTS AND AGENCIES OF THE  
 DEPARTMENT OF DEFENSE

Form Approved  
OMB No 0704-0188

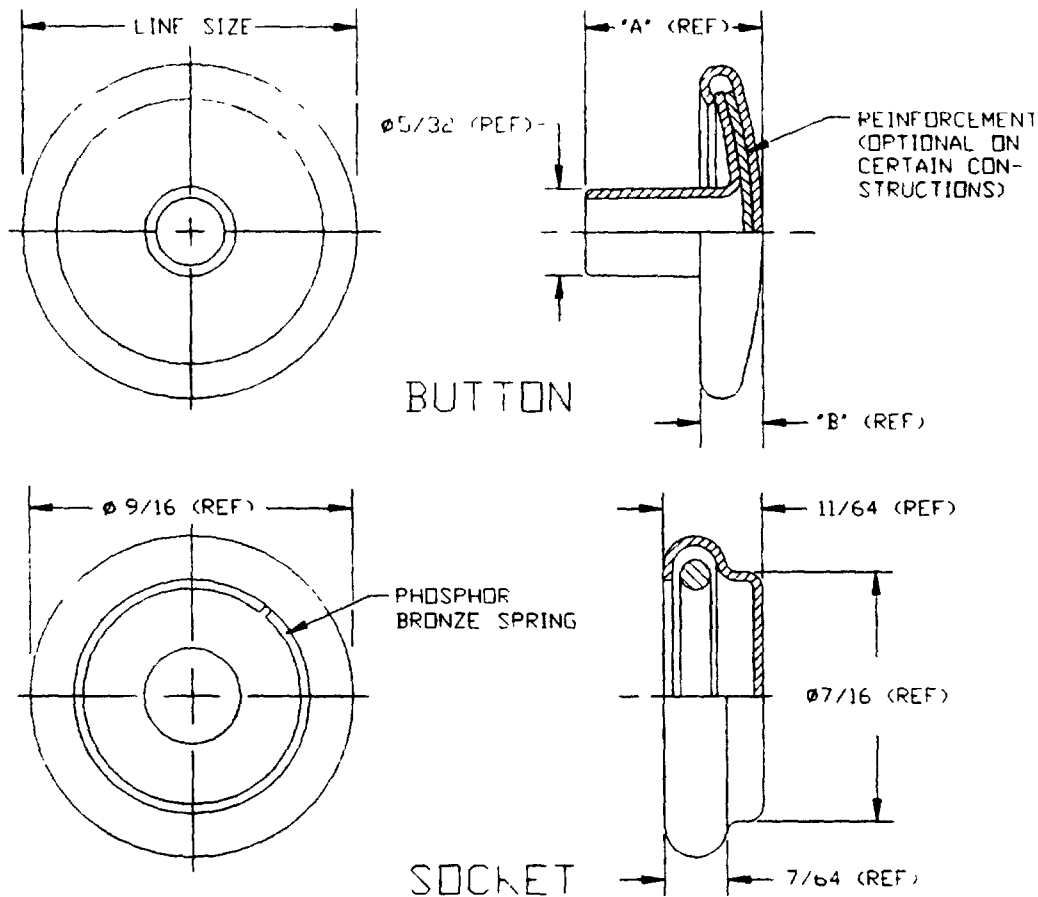

BUTTON	DIM A(REF)	DIM B(REF)	MS PART NUMBER (SEE NOTE 5 ON PAGE 6)			
			BRIGHT BRASS	BLACK	NICKEL PLATE	BRIGHT CHROME
24 LINE (SIZE 1)	9/32	7/64	MS27980-1	MS27980-1B	MS27980-1N	MS27980-1C
24 LINE (SIZE 2)	3/8	7/64		MS27980-2B	MS27980-2N	
36 LINE	19/64	9/64		MS27980-5B	MS27980-5N	
SOCKET	...	...	MS27980-6	MS27980-6B	MS27980-6N	MS27980-6C

NOTE APPLICABLE BUTTON AND SOCKET CONSTITUTE FEMALE HALF OF STYLE 2 FASTENER.

INCH-POUND

PREPARING ACTIVITY DLA-IS CUSTODIANS ARMY- NAVY-AS AIR FORCE - 99 DLA REVIEW AT,AV,ER,MC,OS PROJECT NUMBER 5325 0329	MILITARY SPECIFICATION SHEET TITLE FASTENERS, SNAP, STYLE 2 (REGULAR WIRE SPRING CLAMP TYPE)	SPECIFICATION SHEET NUMBER MS27980 13 JUNE 85 REV F SUPERSEDING MS27980E 30 MAY 1984 AMSC-N/A FSC-5325
DISTRIBUTION STATEMENT A Approved for public release distribution is unlimited		Page 1 of 6

THE REQUIREMENTS FOR ACQUIRING THE PRODUCT(S) DESCRIBED HEREIN SHALL CONSIST OF THIS SPECIFICATION SHEET AND THE ISSUE OF THE FOLLOWING SPECIFICATION LISTED IN THE "ISSUE OF THE DODSS SPECIFIED IN THE SOLICITATION MIL-F-10884"

THIS SPECIFICATION IS APPROVED FOR USE BY ALL DEPARTMENTS AND AGENCIES OF THE DEPARTMENT OF DEFENSE

Form Approved  
OMB No. 0704-0188

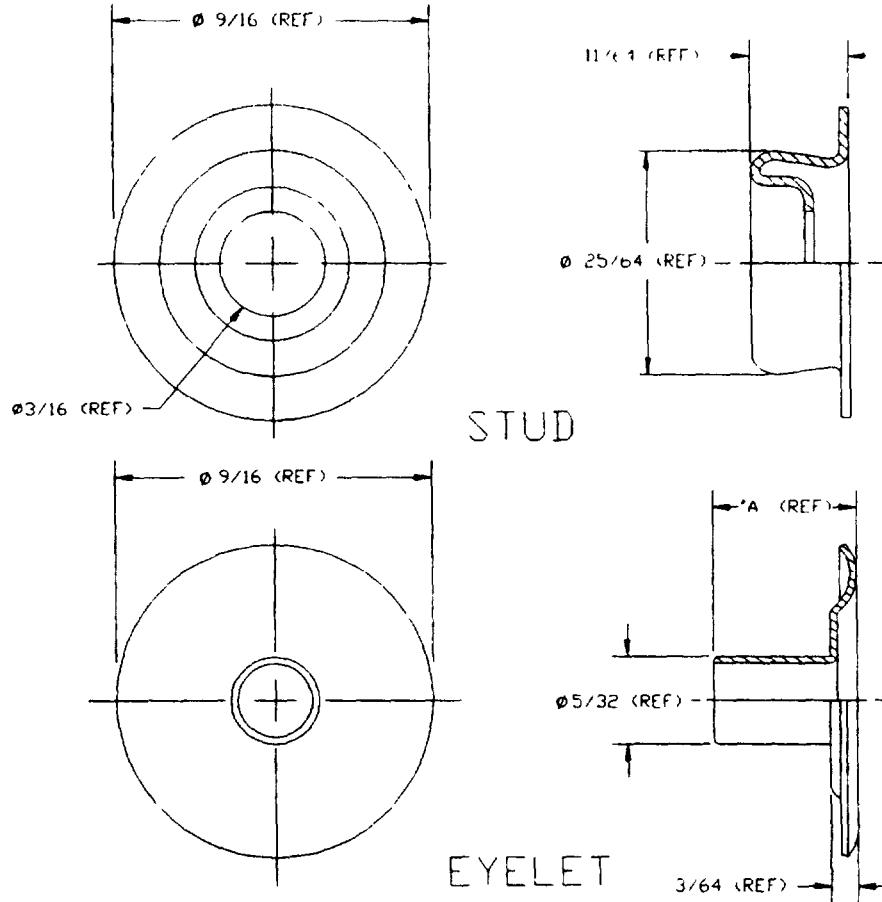

		MS PART NUMBER (SEE NOTE 5 ON PAGE 6)				
	SIZE	DIM A(REF)	BRIGHT BRASS	BLACK	NICKEL PLATE	BRIGHT CHROME
STUD		..	MS27980-7	MS27980-7B	MS27980-7N	MS27980-7C
EYELET	1	9/32	MS27980-8	MS27980-8B	MS27980-8N	
EYELET	2	11/32	MS27980-9	MS27980-9B	MS27980-9N	
EYELET	3	13/32		MS27980-10B	MS27980-10N	

NOTE APPLICABLE STUD AND EYELET CONSTITUTE MALE HALF OF FASTENER OTHER TYPES OF MALE HALVES ARE SHOWN ON SHEET NO'S 3 THROUGH 4

PREPARING ACTIVITY DLA-IS CUSTODIANS ARMY- NAVY-AS AIR FORCE-99 DLA REVIEW AT AVER MC OS	MILITARY SPECIFICATION SHEET TITLE FASTENERS, SNAP, STYLE 2 (REGULAR WIRE SPRING CLAMP TYPE)	SPECIFICATION SHEET NUMBER MS27980 SUPERSEDING MS27980E AMSC- N/A	13 JUNE 95 REV F 30 MAY 1984 FSC -5325
---	---	---	---

DISTRIBUTION STATEMENT A Approved for public release distribution is unlimited

REQUIREMENTS FOR ACQUIRING THE PRODUCT(S) DESCRIBED HEREIN SHALL CONSIST OF THIS SPECIFICATION SHEET AND THE ISSUE OF THE FOLLOWING SPECIFICATION LISTED IN THAT ISSUE OF THE DODISS SPECIFICATION SHEET: THE SOLICITATION MIL-F-10884

THIS SPECIFICATION IS APPROVED FOR USE BY ALL DEPARTMENTS AND AGENCIES OF THE DEPARTMENT OF DEFENSE

Form Approved  
DHB No (1714-0188)

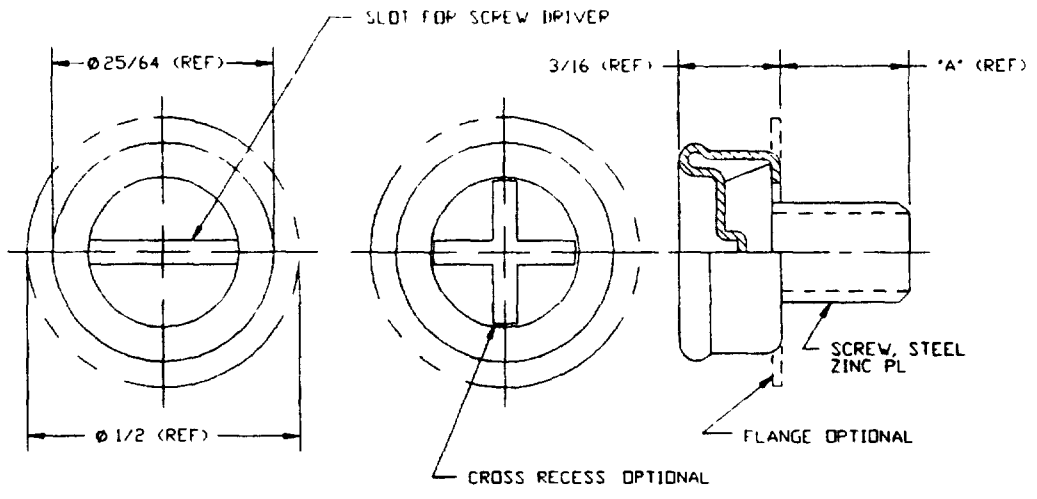

STUD, MACHINE SCREW BASE

MS PART NUMBER (SEE NOTE 5 ON PAGE 6)				
SIZE	DIM A(REF)	THD	BLACK	NICKEL PLATE
1	1/4	NO 8 32UNC -2A	MS27980-11B	MS27980-11N
2	5/16		MS27980-12B	MS27980-12N
3	3/8		MS27980-13B	MS27980-13N
4	5/8		MS27980-14B	MS27980-14N

PREPARING ACTIVITY DLA-IS CUSTODIANS ARMY- NAVY-AS AIR FORCE- 99 DLA REVIEW AT AV ER,MC OS PROJECT NUMBER 5325-0329	MILITARY SPECIFICATION SHEET TITLE FASTENERS, SNAP, STYLE 2 (REGULAR WIRE SPRING CLAMP TYPE)	SPECIFICATION SHEET NUMBER <b>MS27980</b> 13 JUNE 95 REV F SUPERSEDING MS27980E 30 MAY 1984 AMSC- N/A FSC -5325
DISTRIBUTION STATEMENT A Approved for public release distribution is unlimited		Page <u>3</u> of <u>6</u>

THE REQUIREMENTS FOR ACQUIRING THE PRODUCT(S) DESCRIBED HEREIN SHALL CONSIST OF THIS SPECIFICATION SHEET AND THE ISSUE OF THE FOLLOWING SPECIFICATION LISTED IN THAT ISSUE OF THE DODDSS SPECIFICATION SHEET: MIL-F-10884

THIS SPECIFICATION IS APPROVED FOR USE BY ALL DEPARTMENTS AND AGENCIES OF THE DEPARTMENT OF DEFENSE

Form Approved  
OMB No 0704 0188

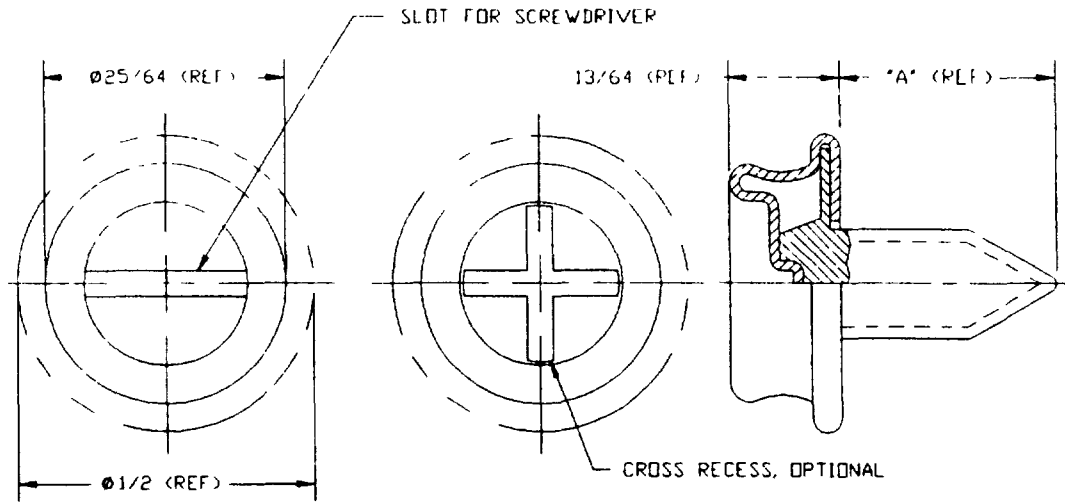

STUD, WOOD SCREW BASE;  
STUD, SELF-TAPPING SCREW BASE;

				MS PART NUMBER (SEE NOTE 5 ON PAGE 6)		
	SIZE	SCREW SIZE	DIM A(REF)	BLACK	NICKEL PLATE	BRIGHT CHROME
STUD, WOOD SCREW BASE		NO 7	5/8	MS27980-19B	MS27980-19N	
STUD, SELF-TAPPING SCREW BASE	1	NO 7	3/8	MS27980-20B	MS27980-20N	MS27980-20C
STUD, SELF-TAPPING SCREW BASE	2	NO 10	5/8	MS27980-21B	MS27980-21N	

PREPARING ACTIVITY DLA-IS CUSTODIANS ARMY- NAVY-AS AIR FORCE-99 DLA- REVIEW AT AV ER,MC,OS	MILITARY SPECIFICATION SHEET TITLE <b>FASTENERS, SNAP, STYLE 2 (REGULAR WIRE SPRING CLAMP TYPE)</b>	SPECIFICATION SHEET NUMBER <b>MS27980</b> 13 JUNE 95 REV F SUPERSEDING MS27980E 30 MAY 1984 AMSC -N/A FSC -5325
PROJECT NUMBER 5325-0329 DISTRIBUTION STATEMENT A Approves for public release distribution is unlimited		Page <u>4</u> of <u>6</u>

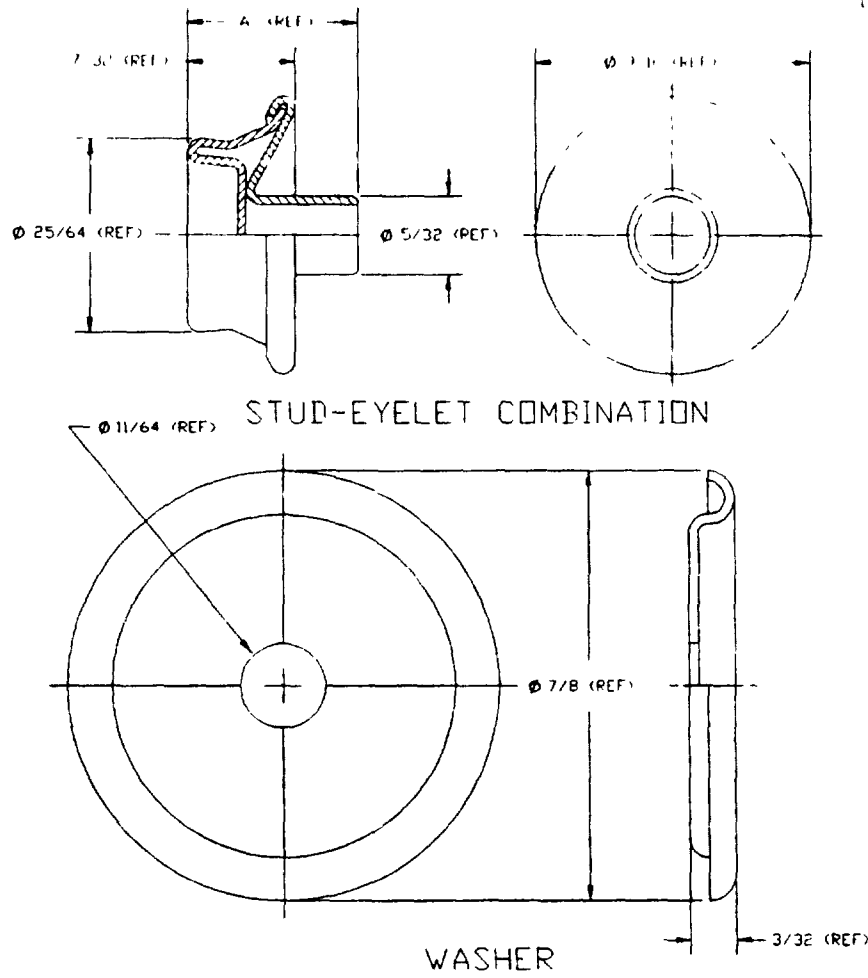

STUD-EYELET COMBINATION

WASHER

	SIZE	DIM A(REF)	MS PART NUMBER (SEE NOTE 5 ON PAGE 6)		
			BRIGHT BRASS	BLACK	NICKEL PLATE
STUD-EYELET COMB	1	11/32	MS27980-26	MS27980-26B	
STUD-EYELET COMB	2	25/64		MS27980-27B	MS27980-27N
WASHER			MS27980-28		

NOTE

- 1 THE STUD-EYELET COMBINATION ABOVE, IN THE APPLICABLE SIZE, CONSTITUTES THE MALE HALF OF THE STYLE 2 FASTENER WHEN THE APPLICATION REQUIRES A REVERSIBLE FASTENER WHEN THE STUD-EYELET COMBINATION IS REQUIRED, THE SOCKET SHOWN ON SHEET NO. 1 OF THIS STANDARD SHALL CONSTITUTE THE FEMALE HALF
- 2 THE WASHER ABOVE IS FOR USE WITH 36 LIGNES STYLE 2 BUTTON WHEN APPLICATION REQUIRES IT

PREPARING ACTMITY DLA-IS CUSTODIANS ARMY- NAVY-AS AIR FORCE-99 DIA REVIEW AT AV ER MC OS PROJECT NUMBER 5365-0329	MILITARY SPECIFICATION SHEET TITLE FASTENERS, SNAP, STYLE 2 (REGULAR WIRE SPRING CLAMP TYPE)	SPECIFICATION SHEET NUMBER MS27980 13 JUNE 95 REV F SUPERSEJING MS27980E 30 MAY 1984 AMSC N/A FSC -5325
DISTRIBUTION STATEMENT A Approved for public release distribution is unlimited		Page 5 of 6

REQUIREMENTS FOR ACQUIRING THE PRODUCT(S) DESCRIBED HEREIN SHALL CONSIST OF THE SPECIFICATION SHEET AND THE ISSUE OF THE FOLLOWING SPECIFICATION LISTED IN THAT ISSUE OF THE DODDS SPECIFIED IN THE SOLICITATION MIL-F-10884

THIS SPECIFICATION IS APPROVED FOR USE BY ALL DEPARTMENTS AND AGENCIES OF THE DEPARTMENT OF DEFENSE

THE REQUIREMENTS FOR ACQUIRING THE PRODUCT(S) DESCRIBED HEREIN SHALL CONSIST OF THIS SPECIFICATION SHEET AND THE ISSUE OF THE FOLLOWING SPECIFICATION LISTED IN THAT ISSUE OF THE CDDISS SPECIFIED IN THE SOLICITATION MIL-F-10884

THIS SPECIFICATION IS APPROVED FOR USE BY ALL DEPARTMENTS AND AGENCIES OF THE DEPARTMENT OF DEFENSE

Form Approved  
OMB No. 0704-0188

**REQUIREMENTS**

- 1 MATERIAL ALL COMPONENTS ARE COMMERCIAL BRASS 7030
- 2 FINISH
  - a BRIGHT BRASS
  - b BLACK
  - c NICKEL PLATE
  - d BRIGHT CHROME PLATE
- 3 COMPONENT PARTS OF THE SAME FASTENER SHALL BE PRODUCED BY THE SAME MANUFACTURER
- 4 PART NUMBER THE PART NUMBER SHALL CONSIST OF THE BASIC MS NUMBER PLUS THE DASH NUMBER

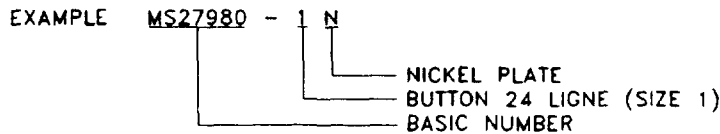

**NOTES**

- 1 DIMENSIONS ARE IN INCHES DIMENSIONS ARE FOR INFORMATION PURPOSES ONLY PRODUCTION DIMENSIONS AND TOLERANCES IN ACCORDANCE WITH DRAWINGS REFERENCED IN MIL-F-10884
- 2 IN THE EVENT OF A CONFLICT BETWEEN THE TEXT OF THIS DOCUMENT AND THE REFERENCES CITED HEREIN, THE TEXT OF THIS DOCUMENT SHALL TAKE PREFERENCE
- 3 UNLESS OTHERWISE SPECIFIED, ISSUES OF REFERENCED DOCUMENTS ARE THOSE IN EFFECT AT THE TIME OF SOLICITATION
- 4 MS27980 SUPERSEDES AN227
- 5 PART NUMBERS LISTED ARE BASED ON CURRENT GOVERNMENT USAGE OTHER PART NUMBERS MAY ALSO BE OBTAINED

PREPARING ACTIVITY DLA-IS CUSTODIANS ARMY- NAVY-AS AIR FORCE-99 DLA- REVIEW AT,AV ER,MC,OS PROJECT NUMBER 5325-0329	MILITARY SPECIFICATION SHEET TITLE FASTENERS, SNAP, STYLE 2 (REGULAR WIRE SPRING CLAMP TYPE)	SPECIFICATION SHEET NUMBER MS27980	13 JUNE 95 REV F
		SUPERSEDING MS27980E	30 MAY 1984
DISTRIBUTION STATEMENT A Approved for public release distribution is unlimited		AMSC- N/A	FSC -5325
			Page 6 of 6