

REQUIREMENTS FOR ACQUIRING THE PRODUCT(S) DESCRIBED HEREIN SHALL CONSIST OF THE SPECIFICATION SHEET AND THE ISSUE OF THE FOLLOWING SPECIFICATION LISTED IN THAT ISSUE OF THE DODDSS SPECIFIED IN THE SOLICITATION: MIL-B-7949

Form Approved
OMB No. 0704-0188

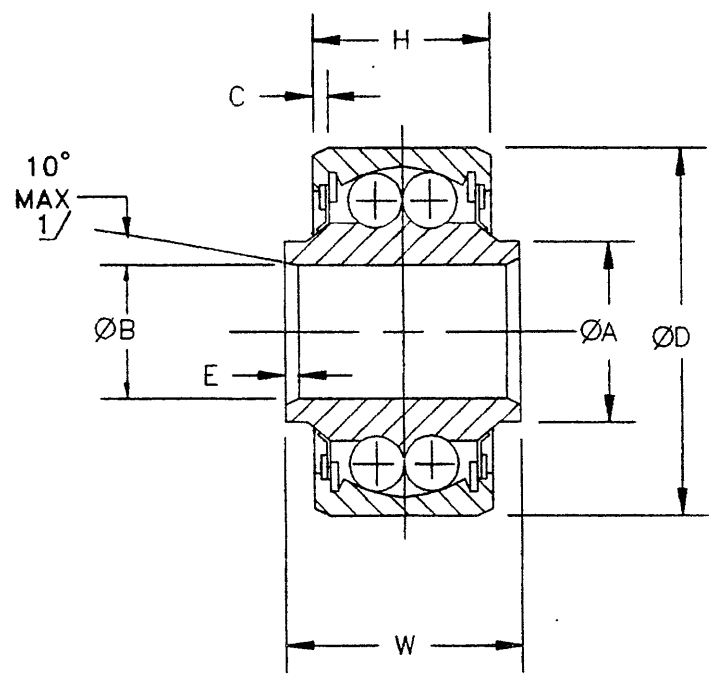

TABLE I. DIMENSIONS AND LOADS

MS DASH NO.	ØB		ØD		W		H		ØA	C		E		LIMIT LOAD RATING		AXIAL INTERNAL CLEARANCE (MAX)	7/ RADIAL LOAD RATING (LBS.) FOR AVERAGE LIFE OF 10,000 COMPLETE 90° CYCLES		WEIGHT POUNDS (APPROX)
	BORE		OUTSIDE DIAMETER		WIDTH INNER RING		WIDTH OUTER RING			5/ OUTER RING CORNER CHAMFER	4/ INNER RING CORNER CHAMFER	RADIAL (LB)	THRUST (LB)	6/ CASE I			E/ CASE II		
	+ .0000	- .0005	+ .0000	- .0005	+ .000	- .005	+ .000	- .005		+ .015	- .000			+ .015	- .000				
-3	.1900	.7774	.500	.392	.304	.022					.005	1420	200	.0055	1420	1220	.04		
-4	.2500	.9014	.687	.464	.430						.032	1780	300		1780	1600	.06		
-5	.3125	1.2500	.812	.656	.515						.032	3740	600	.006	3740	3300	.16		
-6	.3750	1.4375	.937	.750	.564						.015	5100	800		4980	4370	.24		
-8	.5000	1.6875	1.000	.812	.775						.044	7120	1000	.007	6340	5570	.36		
-10	.6250	1.9375	1.125	.937	.869						.044	9000	1300		7780	6860	.53		

(TABLE I, CONTINUED)

MS DASH NO.	MAXIMUM STARTING TORQUE (INCH-OZ)	MINIMUM TORQUE TO DISLodge SEAL (IN/LB)
-3	1	8
-4	1	12
-5	2	28
-6	2	45
-8	3	60
-10	3	78

- 1/ THESE BEARINGS ARE INTERNAL SELF-ALIGNING FOR 10° IN EITHER DIRECTION.
- 2/ DIMENSIONS TO BE MET AFTER PLATING.
- 3/ OUT-OF-ROUND TOLERANCES: BORE: +.0002, -.0007; OUTER DIA: +.0005, -.0010.
- 4/ 45° CHAMFER OR A RADIUS GIVING APPROXIMATELY THE SAME FILLET CLEARANCE WILL BE ACCEPTABLE.
- 5/ 45° CHAMFER OR A RADIUS GIVING APPROXIMATELY THE SAME GRIP FOR STAKING THE BEARING IN THE HOUSING WILL BE ACCEPTABLE.
- 6/ CASE I - LOAD FIXED WITH RESPECT TO OUTER RING. CASE II - LOAD FIXED WITH RESPECT TO INNER RING.
- 7/ THESE RATINGS ARE FOR OPERATION UP TO 250°F. FOR OPERATION UP TO 350°F, THE RATINGS SHALL BE REDUCED BY 20%.

(F) DENOTES CHANGE

INCH-POUND

PREPARING ACTIVITY: NAVY-AS	MILITARY SPECIFICATION SHEET	SPECIFICATION SHEET NUMBER
CUSTODIANS: ARMY-AV NAVY-AS	TITLE	MS27643 21 JUNE 95
AIR FORCE-99 DLA-	BEARING, BALL, AIRFRAME, ANTI-FRICTION, SELF-ALIGNING, DOUBLE ROW, HEAVY DUTY	REV F
REVIEW: ARMY-AR, AT, ME, MI AF-84, DLA-IS		SUPERSEDING MS27643 E 05 DEC 94
USER:		AMSC- N/A FSC 3110
PROJECT NUMBER: 3110-0929		

THIS SPECIFICATION IS APPROVED FOR USE BY ALL DEPARTMENTS AND AGENCIES OF THE DEPARTMENT OF DEFENSE.

THE REQUIREMENTS FOR ACQUIRING THE PRODUCT(S) DESCRIBED HEREIN SHALL CONSIST OF THIS SPECIFICATION SHEET AND THE ISSUE OF THE FOLLOWING SPECIFICATION LISTED IN THAT ISSUE OF THE DODISS SPECIFIED IN THE SOLICITATION: MIL-B-7949

THIS SPECIFICATION IS APPROVED FOR USE BY ALL DEPARTMENTS AND AGENCIES OF THE DEPARTMENT OF DEFENSE.

Form Approved
OMB No. 0704-0188

REQUIREMENTS:

1. MATERIAL: RINGS: 52100 STEEL PER AMS6440, OR E52100 STEEL PER FED-STD-66.
BALLS: 52100 STEEL PER AMS6440 OR 51100 STEEL PER AMS6449, OR E51100 OR E52100 STEEL PER FED-STD-66.
SEALS: POLYTETRAFLUOROETHYLENE PER AMS3652 OR POLYTETRAFLUOROETHYLENE SHEET, GLASS FABRIC REINFORCED PER AMS3666.
SEAL RETAINERS: ANY CORROSION RESISTANT STEEL.
2. LUBRICANT: MIL-G-81322 OR MIL-G-23827. ALL BEARINGS SHALL BE PACKED WITH GREASE CONFORMING TO MIL-G-81322 UNLESS OTHERWISE SPECIFIED. IF MIL-G-23827 IS REQUIRED, ADD THE LETTER "G" AFTER THE MS27643 DASH NUMBER. MIL-G-23827 SHALL NOT BE USED FOR OPERATION WHERE TEMPERATURES EXCEED 250°F.
3. HARDNESS: HEAT TREAT RINGS AND BALLS TO ROCKWELL "C" 60 TO 66 AND STABILIZE FOR OPERATION AT 250°F.
4. SURFACE ROUGHNESS: RACEWAYS AND BALLS SHALL BE 8 MICRINCHES R_a PER ANSI/ASME B46.1.
- (F) 5. PLATING: ALL EXTERNAL SURFACES EXCEPT BORE, SEALS AND SEAL RETAINERS SHALL BE ZINC-NICKEL IN ACCORDANCE WITH AMS 2417, TYPE 2, OR CADMIUM PLATED IN ACCORDANCE WITH QQ-P-416, TYPE I, CLASS 2, WITH A THICKNESS OF .0003 TO .0006 INCHES.
6. RADIAL INTERNAL CLEARANCE: WITHOUT DESIGNATOR "R" THE PART NUMBER INDICATES .0000 TO .0010.
WITH DESIGNATOR "R" THE PART NUMBER INDICATES .0002 TO .0005.
7. PART NUMBER: THE PART NUMBER SHALL BE SEQUENCED LEFT TO RIGHT WITH DESIGNATIONS IN THE FOLLOWING SEQUENCE:
EXAMPLE OF PART NUMBER:
MS27643-4RC = BEARING, BALL AIRFRAME, ANTI-FRICTION, SELF-ALIGNING, DOUBLE ROW, HEAVY DUTY.
.2500 INCH BORE, .0002 TO .0005 INCH RADIAL INTERNAL CLEARANCE
FILLED 80% MINIMUM WITH MIL-G-23827 LUBRICANT, 250° F MAX.
└── LUBRICANT DESIGNATOR (SEE LUBRICANT REQUIREMENTS)
└── RADIAL INTERNAL CLEARANCE DESIGNATOR (SEE RADIAL CLEARANCE REQUIREMENTS)
└── DASH NUMBER (SEE TABLE I)
└── MILITARY SPECIFICATION SHEET NUMBER
8. REMOVABLE SEALS ARE REQUIRED.
9. RADIAL AND LATERAL ECCENTRICITY SHALL BE: FOR THE INNER RING .0010 MAX.
FOR THE OUTER RING .0016 MAX.

NOTES:

1. UNLESS OTHERWISE SPECIFIED, ALL DIMENSIONS ARE IN INCHES.
2. THIS SPECIFICATION TAKES PRECEDENCE OVER ANY OTHER DOCUMENTS REFERENCED HEREIN.
3. REFERENCED DOCUMENTS ARE THE ISSUES IN EFFECT AT THE DATE OF INVITATION FOR BID.
4. THE PARTS COVERED BY MS20206 ARE CANCELLED. USE MS27643 FOR NEW DESIGN AND REPLACEMENT.

PREPARING ACTIVITY: NAVY-AS CUSTODIANS: ARMY-AV NAVY-AS AIR FORCE-99 DLA- REVIEW: ARMY-AR,AT,MC,MI AF-84, DLA-IS USER: PROJECT NUMBER: 3110-0929	MILITARY SPECIFICATION SHEET TITLE BEARING, BALL, AIRFRAME, ANTI-FRICTION, SELF-ALIGNING, DOUBLE ROW, HEAVY DUTY	SPECIFICATION SHEET NUMBER MS27643 21 JUNE 95 REV F	
		SUPERSEDING MS27643 E 05 DEC 94 AMSC- N/A FSC 3110	
DISTRIBUTION STATEMENT A. Approved for public release, distribution is unlimited		Page <u>2</u> of <u>2</u>	