

USER SYMBOLS:
Navy - OS
Army - GL, CR, HE, AT

REVIEWER SYMBOLS:
USAF - 11
Army - AR, MI
DLA - CS

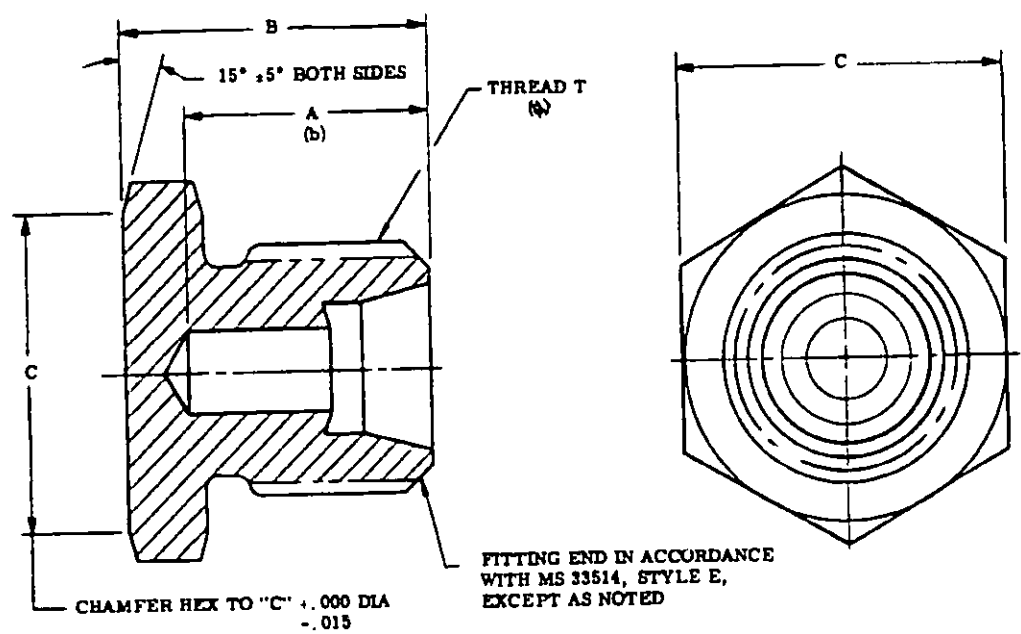

FITTING END IN ACCORDANCE WITH MS 33514, STYLE E, EXCEPT AS NOTED

*Revision/new information is correct as of the date of this document. For future coordination of changes to this document, draft circulation should be based on the information in the current 000193.

DASH NO.	TUBE OD	THREAD T ^{MIN} MIL-B-8879	A -3/64 +0	B	C	WT LB MAX		
						STEEL	AL ALLOY	TI ALLOY
-2	1/8	.3125-24UNJF-3A	3/8	9/16	.438	.014	.005	.008
-3	3/16	.3750-24UNJF-3A	7/16	29/64	+ .003	.017	.006	.009
-4	1/4	.4375-20UNJF-3A		41/64	500	-.004	.020	.007
-5	5/16	.5000-20UNJF-3A	1/2	43/64	583		.026	.010
-6	3/8	.5625-18UNJF-3A		23/32	625		.033	.012
-8	1/2	.7500-18UNJF-3A	9/16	27/32	812	± .004	.067	.024
-10	5/8	.8750-14UNJF-3A	5/8	63/64	938		.107	.038
-12	3/4	1.0625-12UNJ-3A	11/16	1-1/32	1.125	± .005	.174	.062
-18	1	1.3125-12UNJ-3A		1-1/16	1.375		.245	.091
-20	1-1/4	1.6250-12UNJ-3A	5/8		1.688	± .016	.390	.150
-24(b)	1-1/2	1.8750-12UNJ-3A	23/32	1-3/32	2.000		.540	.192
-32(b)	2	2.5000-12UNJ-3A	11/16		2.625	± .020	.965	.354

- (a) PARTS WITH THREADS IN ACCORDANCE WITH MIL-B-7742 OF THE SAME THREAD SIZE, PITCH AND TOLERANCE CLASS CAN BE USED UNTIL STOCKS ARE EXHAUSTED.
- (b) DRILL POINT NOT PERMITTED ON -24 AND -32 SIZES, HOLE SHALL BE FLAT BOTTOMED IN ACCORDANCE WITH DIMENSION A.

FOR DESIGN FEATURE PURPOSES, THIS STANDARD TAKES PRECEDENCE OVER PROCUREMENT DOCUMENTS REFERENCED HEREIN. REFERENCED DOCUMENTS SHALL BE OF THE ISSUE IN EFFECT ON DATE OF INVITATIONS FOR BID.

(E) DENOTES CHANGES

This military standard is approved for use by all Departments & Agencies of the Department of Defense. Selection for all new engineering and design applications and for reissues shall be made from this document.

P.A. NAVY - AS Other Code	INTERNATIONAL INTEREST	TITLE PLUG, FLARELESS TUBE	MILITARY STANDARD MS 21913
USAF-09 ARMY-AV		SUPERSEDES.	SHEET 1 OF 2
PROCUREMENT SPECIFICATION MIL-F-18280			

APPROVED 4 OCT 51
REVISED
D 13 JUL 73
E 26 JUNE 1981

NOTES:

1. MATERIAL: CARBON STEEL - BARS
ALUMINUM ALLOY - BARS
CORROSION RESISTANT STEEL - BARS

SEE PROCUREMENT SPECIFICATION

(E) TITANIUM ALLOY - BARS

2. FINISH: SEE PROCUREMENT SPECIFICATION.
3. BREAK ALL SHARP EDGES AND REMOVE ALL BURRS AND SLIVERS.
4. DIMENSIONS IN INCHES. UNLESS OTHERWISE SPECIFIED, TOLERANCES: FRACTION ±1/64.
5. PART NUMBERS:

NO CODE LETTER IN PART NUMBER FOR CARBON STEEL.

ADD D IN PLACE OF DASH FOR ALUMINUM ALLOY (2024).

ADD W IN PLACE OF DASH FOR ALUMINUM ALLOY (7075).

ADD J IN PLACE OF DASH FOR CORROSION RESISTANT STEEL, TYPE 304.

ADD K IN PLACE OF DASH FOR CORROSION RESISTANT STEEL, TYPE 316.

ADD S AFTER DASH NUMBER FOR CORROSION RESISTANT STEEL, TYPE 347. PARTS ARE NOT TO BE MANUFACTURED FROM TYPE 304L STEEL.

(E) ADD T AFTER DASH NUMBER FOR TITANIUM ALLOY (6AL-4V).

EXAMPLES OF PART NUMBERS:

MS21913-4 - PLUG, 1/4 TUBING, CARBON STEEL.

MS21913D4 - PLUG, 1/4 TUBING, ALUMINUM ALLOY (2024).

MS21913W4 - PLUG, 1/4 TUBING, ALUMINUM ALLOY (7075).

MS21913J4 - PLUG, 1/4 TUBING, CORROSION RESISTANT STEEL, TYPE 304.

MS21913K4 - PLUG, 1/4 TUBING, CORROSION RESISTANT STEEL, TYPE 316.

MS21913-4S - PLUG, 1/4 TUBING, CORROSION RESISTANT STEEL, TYPE 347.

(E) MS21913-4T - PLUG, 1/4 TUBING, TITANIUM ALLOY (6AL-4V).

(E) 6. ~~PARTS CODED C ARE INACTIVE FOR DESIGN AFTER 31 JUNE 1967. PARTS CODED C MAY BE USED UNTIL STOCKS ARE EXHAUSTED. PARTS CODED J OR K MAY BE USED IN LIEU OF PARTS CODED C.~~

(E) ITEMS CODED "C" ON PREVIOUS ISSUES OF THIS STANDARD ARE NO LONGER TO BE FURNISHED. UNLESS OTHERWISE SPECIFIED, PARTS CODED J, K, OR S (AT SUPPLIER'S OPTION) SHALL BE FURNISHED IN LIEU OF "C" CODED PARTS.

(E) 7. TITANIUM NOT RECOMMENDED FOR USE IN OXYGEN SYSTEMS.

* CERTAIN PROVISIONS (SCREW THREADS, HEXAGON SIZE AND UNDERCUT DIMENSIONS) OF THIS STANDARD ARE THE SUBJECT OF INTERNATIONAL STANDARDIZATION AGREEMENT ASCC AIR STD 17/15. WHEN REVISION OR CANCELLATION OF THIS STANDARD IS PROPOSED WHICH WILL AFFECT OR VIOLATE THE INTERNATIONAL AGREEMENT CONCERNED, THE PREPARING ACTIVITY WILL TAKE APPROPRIATE RECONCILIATION ACTION THROUGH INTERNATIONAL STANDARDIZATION CHANNELS, INCLUDING DEPARTMENTAL STANDARDIZATION OFFICES, IF REQUIRED.

APPROVED 4 OCT 51
REVISED (E) FOR CHANGES SEE SHEET 1 AND 2

User activities:
Navy - OS
Army - CL, CR, ME, AT

Review activities:
USAF - 11
Army - AR, ME
DLA - CS

This military standard is approved for use by all Departments & Agencies of the Department of Defense. Satisfaction for all new engineering and design applications and for retooling etc shall be made from this document.

P.A. Other Code USAF-99 ARMY-AV	INTERNATIONAL INTEREST	TITLE	MILITARY STANDARD
		PLUG, FLARELESS TUBE	MS21913
PROCUREMENT SPECIFICATION MIL-F-18280	SUPERSEDES:	SHEET 2 OF 2	