

THE REQUIREMENTS FOR ACQUIRING THE PRODUCT(S) DESCRIBED HEREIN SHALL CONSIST OF THIS SPECIFICATION SHEET AND THE ISSUE OF THE FOLLOWING SPECIFICATION LISTED IN THAT ISSUE OF THE DOORS SPECIFIED IN THE SOLICITATION:

THIS SPECIFICATION IS APPROVED FOR USE WITHIN THE DEPARTMENT OF THE AIR FORCE AND IS AVAILABLE FOR USE BY ALL DEPARTMENTS AND AGENCIES OF THE DEPARTMENT OF DEFENSE.

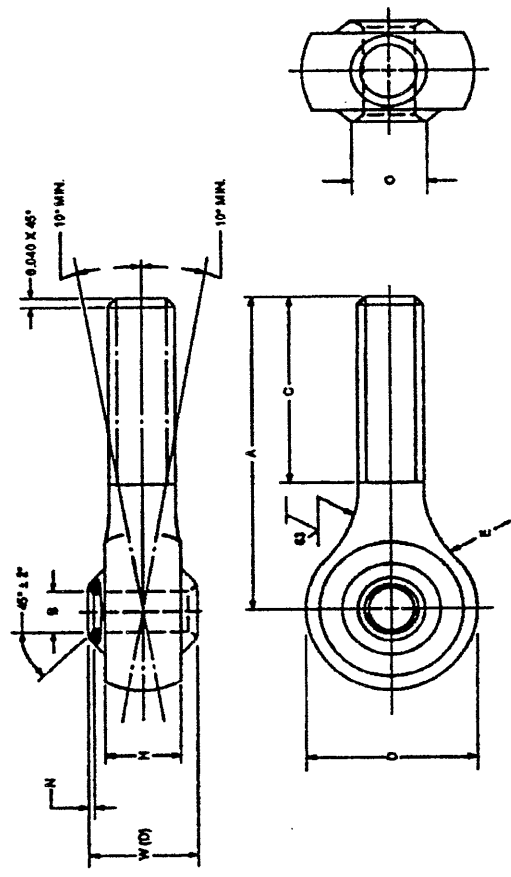

Form Approved
OMB No. 0704-0188

DASH NUMBER	PORE SIZE NOM.	A	B	C	D	E	M	N	O	T	W	WGT. LIB. APPROX.
-1		1.375		0.750	0.781	0.422	0.328		0.276	0.1900 - 20LN 0.1900 - 20FH	0.437	0.04
-2		2.031		1.313	0.908	0.500	0.407		0.299		0.500	
-3			0.1000					0.005		0.3750 - 24NH		
-4	NO.10	1.375		0.750	0.781	0.390	0.328		0.276	0.3750 - 24LN	0.437	0.05
-5		1.812		0.938		0.562	0.431		0.307	0.2500 - 20NH	0.500	0.10
-6		1.963		1.000		0.344	0.328		0.276		0.437	0.05
-7									0.340	0.3750 - 24NH		
-8	1/4	1.875	0.2500	1.125	0.928	0.488	0.438	0.005	0.501	0.3750 - 24LN	0.943	0.19
-9										0.3750 - 24NH		
-10		2.438	0.3125	1.543	1.360	0.500	0.658	0.015	0.501	0.4375 - 20NH	0.870	0.24
-11	5/16									0.525 - 18NH		
-12		2.750	0.6250	1.508	2.008	0.500	0.933	0.015	0.375	0.525 - 18NH	1.125	0.71
-13	5/8											

PREPARING ACTIVITY: AF-84
CUSTODIANS: ARMY - AV NAVY - AS AF-88
REVIEWER: ARMY - AR, AT, M DLA-4S
USER: ARMY-ME
PROJECT NUMBER: 3110-0821-02
PROCUREMENT SPECIFICATION: MIL-B-6039

TITLE: MILITARY SPECIFICATION SHEET
BEARING, BALL, ROD END, DOUBLE ROW, PRECISION, EXTERNAL THREAD, SELF-ALIGNING, AIRFRAME, TYPE II, -45° TO 300° F

SPECIFICATION SHEET NUMBER: MS21151
SUPERSEDING:
AMSC - N/A FSC - 3110

DISTRIBUTION STATEMENT A: APPROVED FOR PUBLIC RELEASE; DISTRIBUTION IS UNLIMITED. Page 1 of 2

APPROVED
REVISED 7 JULY 71 1 MAY 81 19 JUL 82 23 MARCH 84

- NOTES:**
- FOR DESIGN FEATURE PURPOSES, THIS STANDARD TAKES PRECEDENCE OVER ANY OTHER DOCUMENTS REFERENCED HEREIN
 - REFERENCED DOCUMENTS SHALL BE OF THE ISSUE IN EFFECT ON DATE OF INVITATIONS FOR BID.

REQUIREMENTS:

- TOL - 0.000 - 0.015
- A RADIUS GIVING THE SAME FILLET CLEARANCE WILL BE ACCEPTABLE
 - THREADS SHALL CONFORM TO UN JF-3A PER MIL-S-4479
 - THREAD LENGTH SHALL BE TOTAL LENGTH "C" ALLOWING MAXIMUM OF TWO IMPERFECT THREADS.
 - KEYWAY SLOT IF REQUIRED SHALL BE IN ACCORDANCE WITH NAS 513 AND SHALL BE DESIGNATED BY ADDING SUFFIX "C" TO THE DASH NUMBER (-3 THROUGH -13 ONLY)
 - 10° ALLOWED MISALIGNMENT SHALL OCCUR WITHOUT INTERFERENCE BETWEEN BALL HOUSING AND SURFACES INDICATED BY DIMENSION "W"
 - CASE I = LOAD FIXED WITH RESPECT TO OUTER RACE (AVERAGE LIFE RATINGS)
CASE II = LOAD FIXED WITH RESPECT TO INNER RACE (AVERAGE LIFE RATINGS)
 - THESE RATINGS ARE FOR OPERATIONS UP TO 250° F MAX. WHEN SUBJECTED TO OPERATION ABOVE 250° F, THE RATINGS SHOULD BE REDUCED BY 20%.
- FOR DEFINITION AND APPLICATION OF DRAWING STATUS NOTES, SEE MIL-STD-882.
 - RADIAL PLAY: 0.0000 - 0.0004 UNDER 5.5 POUND GAGE LOAD.
 - AXIAL PLAY: 0.0000 - 0.003 UNDER 5.5 POUND GAGE LOAD.
 - MATERIAL: INNER RACE & BALLS - AISI E52100 STEEL PER MIL-S-7420; OUTER RACE & SHANK - AISI 4130 STEEL PER MIL-S-4754; OR AISI 5210 STEEL PER MIL-S-8660; SEALS - POLYTETRAFLUORETHYLENE PER AMS 3625 OR AMS 3686; SEAL RETAINERS - STEEL, CORROSION RESISTANT, AISI 301 OR AISI 430.
 - HEAT TREATMENT: HEAT TREAT INNER RINGS & BALLS TO ROCKWELL "C" 60 TO 66, OUTER RING RACEWAYS TO ROCKWELL "C" 58-62; STABILIZE FOR OPERATION AT 250° F.
 - FINISH: Z-NI PLATE PER AMS 2417, TYPE 2. EXTERNAL SURFACES SHALL BE PLATED TO A THICKNESS OF 0.00030 - 0.00040 INCHES EXCEPT EXTERNAL THREADS WHICH SHALL BE 0.00020 - 0.00050 INCHES.
 - LUBRICANT: MIL-G-81322 OR MIL-G-23427. ALL BEARINGS SHALL BE PREPACKED 80% FULL WITH GREASE QUALIFIED TO MIL-G-81322 UNLESS MIL-G-23427 IS REQUIRED. IF MIL-G-23427 IS REQUIRED, ADD THE SUFFIX Q TO THE MS PART NUMBER AND LIMIT BEARING OPERATION TO NOT MORE THAN 250° F.
 - REMOVE ALL BURRS AND SHARP EDGES.
 - SURFACE ROUGHNESS: RACEWAYS AND BALLS SHALL NOT EXCEED 8 MICRO INCHES (AA). SHANK 63 MICRO INCHES (AA).
 - DIMENSIONS: IN INCHES, UNLESS OTHERWISE SPECIFIED.
 - DIMENSIONS TO BE MET AFTER PLATING.
 - EXAMPLE OF COMPLETE PART NUMBER: MS21151-4C, BEARING, BALL, ROD END, EXTERNAL RIGHT HAND THREAD, CONTACT SEAL, WITH NAS 513 KEYWAYSLOT.
 - RECLAIMED MATERIALS SHALL BE REQUIRED TO THE MAXIMUM EXTENT POSSIBLE.

THE REQUIREMENTS FOR ACQUIRING THE PRODUCT(S) DESCRIBED HEREIN SHALL CONSIST OF THIS SPECIFICATION SHEET AND THE ISSUE OF THE FOLLOWING SPECIFICATION LISTED IN THAT ISSUE OF THE DOORS SPECIFIED IN THE SQUADRATION:

THIS SPECIFICATION IS APPROVED FOR USE WITHIN THE DEPARTMENT OF THE AIR FORCE AND IS AVAILABLE FOR USE BY ALL DEPARTMENTS AND AGENCIES OF THE DEPARTMENT OF DEFENSE.

ENGINEERING DATA							
DASH NUMBER	RADIAL STRENGTH		AXIAL STRENGTH		RADIAL LOAD RATING 10,000 COMPLETE 90° CYCLES (M) (7)		MAXIMUM STARTING TORQUE IN-OZ
	LIMIT LOAD LBS	FRACTURE LOAD LBS	LIMIT LOAD LBS	FRACTURE LOAD LBS	CASE I	CASE II	
-1	1000	1500	200	300	1000	1000	1
-2							
-3							
-4							
-5	1000	1500	200	300	1000	1000	1
-6							
-7							
-8	1720	2560	345	520	1720	1720	1
-9							
-10	2920	4375	585	880	2920	2600	6
-11							
-12							
-13	7090	10,600	1420	2130	6160	5340	8

PREPARING ACTIVITY: AF-84 CUSTODIANS: ARMY - AV NAVY - AS AF-99 REVIEWER: ARMY - AR, AT, MI DLA-IS USER: ARMY-ME PROJECT NUMBER: 3110-0821-02 PROCUREMENT SPECIFICATION: MIL-B-6039	MILITARY SPECIFICATION SHEET TITLE: BEARING, BALL, ROD END, DOUBLE ROW, PRECISION, EXTERNAL THREAD, SELF-ALIGNING, AIRFRAME, TYPE II, -88° TO 300° F	SPECIFICATION SHEET NUMBER MS21151 SUPERSEDING: AMSC - N/A FSC - 3110
DISTRIBUTION STATEMENT A: APPROVED FOR PUBLIC RELEASE; DISTRIBUTION IS UNLIMITED.		Page 2 of 2

APPROVED REVISED (A) 7 JULY 71 (B) 18 AUG 82 (C) 23 MARCH 84