

DRILL NO 50  
(.065 - .075)  
CSINK 90° X .094

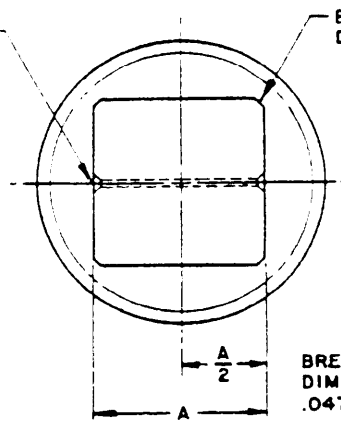

BREAK CORNERS  
DIM N

BREAK CORNERS  
DIM N  
.047 RAD, OPTIONAL

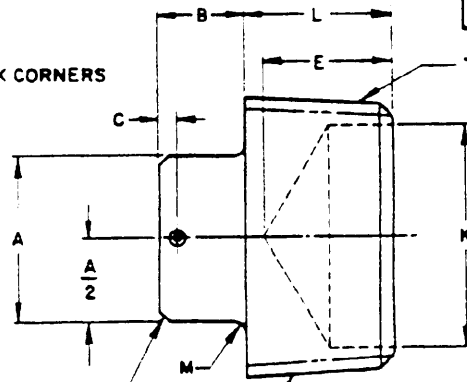

THREAD T

FITTING END IN ACCORDANCE  
WITH MS33677, STYLE A,  
FOR APPLICABLE PIPE THREAD.

Review activities: ARMY - ME, MI, GL  
DLA - CS  
User activities: ARMY - AV

DASH NO	THREAD T NPT	A +.002 -.010	B	C	E MAX	K MAX DIA	L	M RAD	N MAX
0	1/16-27	.188	.188	.094			.312	.031	.010
1	1/8-27	.281	.250	.125			.328	.062	
2	1/4-18	.375	.281				.484		
3	3/8-18	.438	.312		.359	.375			
4	1/2-14	.563	.375		.500	.531	.625		
6	3/4-14	.625	.438			.719	.641		
8	1-11-1/2	.813	.500		.656	.938	.797		
10	1-1/4-11-1/2	.938	.562			1.250	.828		
12	1-1/2-11-1/2	1.125	.625		.672	1.469			
16	2-11-1/2	1.313	.688		.688	1.906	.859		
20	2-1/2-8	1.500	.750		1.125	2.031	1.297		.047

This military standard is approved by the Department and Agencies of the Department of Defense. Substitution for all new engineering and design applications and for repetitive use shall be made from this document.

APPROVED 10 JAN 87 REVISED A 24 MAY 87 B 10 FEB 87 C 25 FEB 77 D 16 JUN 78 E 21 MAR 79 F 2 SEP 82 G 19 JUL 84

P.A. AIR FORCE - 82	TITLE	MILITARY STANDARD
Other ARMY - AR NAVY - AS AIR FORCE - 99	PLUG, PIPE	MS20913
PROCUREMENT SPECIFICATION MIL - F - 5509	SUPERSEDES: AN913	SHEET 1 OF 2

MATERIAL: ALUMINUM ALLOY; COPPER ALLOY; STEEL; CORROSION RESISTANT STEEL (CRES);  
(SEE PROCUREMENT SPECIFICATION).  
FINISH: SEE PROCUREMENT SPECIFICATION.  
NO. CODE LETTER IN PART NUMBER FOR COPPER ALLOY.  
ADD D AFTER DASH NO. FOR ALUMINUM ALLOY (EXCEPT 7075-T73).  
ADD S AFTER DASH NO. FOR STEEL.  
ADD J AFTER DASH NO. FOR CRES, TYPE 304.  
ADD K AFTER DASH NO. FOR CRES, TYPE 316.  
ADD W AFTER DASH NO. FOR 7075-T73 ALUMINUM ALLOY.

EXAMPLE OF PART NUMBERS:  
MS20913-6 - PLUG, 3/4 PIPE THREAD, COPPER ALLOY.  
MS20913-6D - PLUG, 3/4 PIPE THREAD, ALUMINUM ALLOY (EXCEPT 7075-T73).  
MS20913-6J - PLUG, 3/4 PIPE THREAD, CRES, TYPE 304.  
MS20913-6K - PLUG, 3/4 PIPE THREAD, CRES, TYPE 316.  
MS20913-6S - PLUG, 3/4 PIPE THREAD, STEEL.  
MS20913-6W - PLUG, 3/4 PIPE THREAD, 7075-T73 ALUMINUM ALLOY.

BREAK ALL SHARP EDGES AND REMOVE ALL HANGING BURRS AND SLIVERS WHICH MIGHT BECOME DISLODGED UNDER USAGE.

(G) AT OPTION OF MANUFACTURER, THE DASH 0 AND DASH 1 SIZES MAY BE FURNISHED WITHOUT MARKING.  
DIMENSIONS IN INCHES. UNLESS OTHERWISE SPECIFIED, TOLERANCES: DECIMALS  $\pm .016$ , ANGLES  $\pm 5^\circ$ .  
THIS STANDARD TAKES PRECEDENCE OVER DOCUMENTS REFERENCED HEREIN.  
REFERENCED DOCUMENTS SHALL BE OF THE ISSUE IN EFFECT ON DATE OF INVITATIONS FOR BID.

Review activities: ARMY - ME, MT, GL User activities: ARMY - AV  
DLA - CS

APPROVED 10 JAN 67 REVISED (E) FOR CHANGES SEE PAGES 1 & 2. 21 MAR 79 (F) 2 SEP 82 (G)

This military standard is approved by the Department and Agencies of the Department of Defense. Sections for all new engineering and design applications and for repetitive use shall be made from this document.

P.A. AIR FORCE - 82 Other Code ARMY - AR NAVY - AS AIR FORCE - 99	TITLE  <b>PLUG, PIPE</b>	<b>MILITARY STANDARD</b>  <b>MS20913</b>
PROCUREMENT SPECIFICATION MIL - F - 5509	SUPERSEDES: AN913	SHEET 2 OF 2