

INCH-POUND

MS16995H
25 April 1997
SUPERSEDING
MS16995G
27 June 1995

MILITARY SPECIFICATION SHEET

SCREW, CAP, SOCKET HEAD- HEXAGON,
CORROSION RESISTANT STEEL, UNC-3A

This specification is approved for use by all Departments and Agencies of the Department of Defense.

The requirements for acquiring the product described herein shall consist of this specification sheet and the issue of the following specification listed in that issue of the Department of Defense Index of Specifications and Standards (DODISS) specified in the solicitation: FF-S-86.

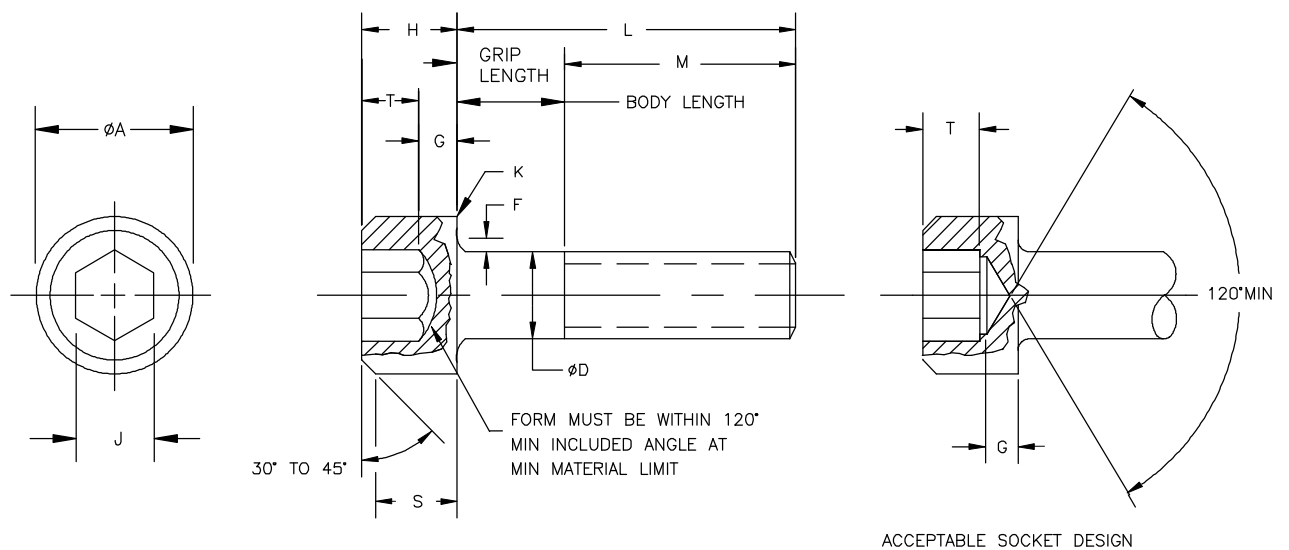

FIGURE 1. Dimensions and configurations.

MS16995H

NOTES: TABLE I. DIMENSIONS AND DASH NUMBERS

Nominal Size		#2 (.0860)			#4 (.1120)			#6 (.1380)		
Threads Per Inch		56 UNC-3A			40 UNC-3A			32 UNC-3A		
ØD Body	Max	.0860			.1120			.1380		
	Min	.0822			.1075			.1329		
ØA Head	Max	.140			.183			.226		
	Min	.134			.176			.218		
H Head Height	Max	.086			.112			.138		
	Min	.083			.108			.134		
S Head Side Height	Min	.077			.101			.124		
J Socket Width Across Flats	Max	.0791			.0952			.1111		
	Min	.0781			.0937			.1094		
T Key Engagement	Min	.038			.051			.064		
G Wall Thickness	Min	.029			.038			.047		
K Chamfer or Radius	Max	.003			.005			.005		
F Fillet Extension	Max	.008			.009			.010		
	Min	.004			.005			.006		
M Basic Thread Length 1_/	Ref	.625			.7500			.7500		
Min Tensile Strength Load Lbs		300			480			730		
L Length	Tolerance	Dash No	Grip Length Max	Body Length Min	Dash No	Grip Length Max	Body Length Min	Dash No	Grip Length Max	Body Length Min
.188	+.000 -.030	1								
.250		2			9			16		
.375		3			10			17		
.500		4			11			18		
.625					12			19		
.750					13			20		
1.000								21		

1_/ See note 2.

MS16995H

TABLE I. DIMENSIONS AND DASH NUMBERS - continued

Nominal Size		#8 (.1640)			#10 (.1900)			1/4 (.250)		
Threads Per Inch		32 UNC-3A			24 UNC-3A			20 UNC-3A		
ØD Body	Max	.1640			.1900			.2500		
	Min	.1585			.1840			.2435		
ØA Head	Max	.270			.312			.375		
	Min	.262			.303			.365		
H Head Height	Max	.164			.190			.250		
	Min	.159			.185			.244		
S Head Side Height	Min	.148			.171			.225		
J Socket Width Across Flats	Max	.1426			.1587			.1900		
	Min	.1406			.1562			.1875		
T Key Engagement	Min	.077			.090			.120		
G Wall Thickness	Min	.056			.065			.095		
K Chamfer or Radius	Max	.005			.005			.008		
F Fillet Extension	Max	.012			.014			.014		
	Min	.007			.009			.009		
M Basic Thread Length	1_/ Ref	.875			.875			1.000		
Min Tensile Strength Load Lbs		1,120			1,400			2,540		
L Length	Tolerance	Dash No	Grip Length Max	Body Length Min	Dash No	Grip Length Max	Body Length Min	Dash No	Grip Length Max	Body Length Min
.375	+.000 -.030	25			35			47		
.500		26			36			48		
.625		27			37			49		
.750		28			38			50		
.875		29			39			51		
1.000		30			40			52		
1.250	+.000 -.040				41	.375	.167	53		
1.500					42	.375	.167	54	.500	.250
1.750								55	.500	.250
2.000								56	1.000	.750

1_/ See note 2.

MS16995H

TABLE I. DIMENSIONS AND DASH NUMBERS - continued

Nominal Size		5/16(.3125)	3/8 (.375)			1/2 (.500)					
Threads Per Inch		18 UNC-3A	16 UNC-3A			13 UNC-3A					
ØD Body	Max	.3125	.3750			.5000					
	Min	.3053	.3678			.4919					
ØA Head	Max	.469	.563			.750					
	Min	.457	.550			.735					
H Head Height	Max	.313	.375			.500					
	Min	.306	.368			.492					
S Head Side Height	Min	.281	.337			.450					
J Socket Width Across Flats	Max	.2530	.3160			.3790					
	Min	.2500	.3125			.3750					
T Key Engagement	Min	.151	.182			.245					
G Wall Thickness	Min	.119	.143			.190					
K Chamfer or Radius	Max	.008	.008			.010					
F Fillet Extension	Max	.017	.020			.026					
	Min	.012	.015			.020					
M Basic Thread Length 1_/	Ref	1.125	1.250			1.500					
Min Tensile Strength Load Lbs		4,190			6,200			11,300			
L Length	Tolerance		Dash No	Grip Length Max	Body Length Min	Dash No	Grip Length Max	Body Length Min	Dash No	Grip Length Max	Body Length Min
	Size 5/16 (.3125) and 3/8 (.375)	Size 1/2 (.500)									
.375	+.000	+.000	61			77			92		
.500											
.625											
.750											
.875											
1.000	+.000	+.000	66			81			94		
1.250											
1.500											
1.750											
2.000											
2.250	+.000	+.000	69	.625	.347	84	.500	.187	97		
2.500											
2.750	+.000	+.000	71	1.125	.847	86	1.000	.687	99	.750	.365
3.000											
	-.060	-.080	70	1.125	.847	87	1.000	.687	100	.750	.365
	-.060	-.080							101	.750	.365
									102	1.500	1.115

1_/ See note 2

MS16995H

TABLE I. DIMENSIONS AND DASH NUMBERS - continued

Nominal Size		#5/8(.625)		
Threads Per Inch		11 UNC-3A		
ØD Body	Max	.6250		
	Min	.6163		
ØA Head	Max	.936		
	Min	.921		
H Head Height	Max	.625		
	Min	.616		
S Head Side Height	Min	.562		
J Socket Width Across Flats	Max	.5050		
	Min	.5000		
T Key Engagement	Min	.307		
G Wall Thickness	Min	.238		
K Chamfer or Radius	Max	.010		
F Fillet Extension	Max	.032		
	Min	.024		
M Basic Thread Length 1_/ Ref		1.750		
Min Tensile Strength Load Lbs		18,100		
L Length	Tolerance	Dash No	Grip Length Max	Body Length Min
1.000	+.000, -.030	107		
1.250		108		
1.500		109		
1.750		110		
2.000		111		
2.250		112		
2.500	+.000, -.080	113	.750	.295
2.750		114	.750	.295
3.000		115	.750	.295

1_/ See note 2.

NOTES:

1. All dimensions are in inches.
2. The basic thread length "M" (Table I) is a referenced value controlled by the grip length and "L" length as specified.
3. MS16995 supersedes MS35461 in part.
4. In the event of a conflict between the text of this document and the references cited herein, the text of this document shall take precedence.
5. Unless otherwise specified, issues of referenced documents are those in effect at the time of solicitation.
6. MS16995 Socket Head Cap Screws manufactured prior to 25 April 1997 may be used until stock is depleted.

REQUIREMENTS:

1. MATERIAL:

Austenitic Corrosion-Resistant Steel screws shall be manufactured from Type 304 (UNS S30400), Type 304L (UNS S30403), Type 305 (UNS S30500), Type 316 (UNS S31600), Type 316L (UNS S31603), Type 384 (UNS S38400), or Type XM-7(UNS S30430) in accordance with the chemical compositions specified in ASTM F 593.
(See Material Identification Marking and Material Code).

2. FINISH:

Passivate in accordance with QQ-P-35 or
Black Oxide coating in accordance with MIL-C-13924, Class 4. (Except for Type 316 or Type 316L).
(See Finish Code).

3. MECHANICAL PROPERTIES:

The minimum tensile strength in load pounds, indicated for each size in Table I, is based on 80,000 PSI minimum tensile strength. Load pounds are calculated by the stress areas indicated in FED-STD-H28/2. The yield strength, based on 0.2 percent offset, shall be 30,000 PSI minimum. The minimum hardness shall be HRB 80.

4. MAGNETIC PERMEABILITY:

When specified, screws shall have a magnetic permeability of less than 2.0 (air = 1.0) for a field strength $H = 200$ oersteds using a magnetic permeability indicator per ASTM A 342.

Note: Cold worked screws may not be capable of meeting permeability and strength requirements simultaneously.

5. THREADS:

Screw threads shall be Unified external threads Class 3A UNC in accordance with FED-STD-H28/2. Acceptability of screw threads shall be in accordance with FED-STD-H28/20, System 22. Screws above the dashed lines shall have complete (full form) threads extended to within two (2) threads of the head as measured with a thread ring gage.

6. HEAD STYLE:

Head of screw may be plain or knurled at manufacturer's option.

7. MANUFACTURER IDENTIFICATION MARKING:

Screws nominal size #10 (.1900) and larger shall be permanently marked with the manufacturer's symbol. Marking size, type, and location of marks at manufacturer's option. Screws shall not be marked on bearing surfaces. Markings shall be raised or depressed on the screw head.

8. MATERIAL IDENTIFICATION MARKING:

Type 316 (UNS S31600) or 316L (UNS S31603) CRES screws nominal size #10 (.1900) and larger shall be permanently marked "316". Markings shall be raised or depressed on the screw head at the manufacturer's option.

9. MATERIAL CODE:

For 300 Series CRES - No code after dash number indicates any 300 Series Austenitic Corrosion-Resistant Steel listed in material requirement.

For Type 316 or 316L CRES - "S316" after dash number indicates Austenitic Corrosion-Resistant Steel

Type 316 or Type 316L.

10. FINISH CODE:

Passivate - No code letter after dash number, or after material code (if applicable), indicates passivate.

Black Oxide - "B" after dash number indicates black oxide coating (except for Type 316 or 316L CRES).

11. PART NUMBER:

The part number shall consist of the basic MS number, followed by a dash number from Table I, a material code (if applicable), and a finish code (if applicable).

EXAMPLES: MS16995-1 indicates Screw, Cap, Socket Head, Hexagon, 300 Series Corrosion-Resistant Steel; .0860-56 UNC-3A Nominal Thread Size, .188 Length, Passivated
MS16995-1S316 indicates Screw, Cap, Socket Head, Hexagon, Corrosion-Resistant Steel Type 316 or Type 316L; .0860-56 UNC-3A Nominal Thread Size, .188 Length, Passivated
MS16995-1B indicates Screw, Cap, Socket Head, Hexagon, 300 Series Corrosion-Resistant Steel; .0860-56 UNC-3A Nominal Thread Size, .188 Length, Black Oxide Coating

The screws covered by dash numbers given in MS35461 that are replaced by applicable dash numbers in this document are canceled after 5 April 62. Use the dash numbers given in the preceding sheets. The canceled screws cannot always replace the new screws and should be used until existing stocks are depleted. Use only the new screws for design and replacement. Replacement shall be in accordance with this table. Interchangeability information regarding part numbers on superseded drawings are also contained in this table.

TABLE II. INTERCHANGEABILITY TABLE

Part Numbers		Part Numbers		Part Numbers	
Canceled	Superseding	Canceled	Superseding	Canceled	Superseding
MS35461	MS16995	MS35461	MS16995	MS35461	MS16995
Dash Number	Dash Number	Dash Number	Dash Numbers	Dash Number	Dash Numbers
1	25	23	49	54	83
2	26	24	50	55	84
3	27	25	51	56	85
4	28	26	52	57	86
5	29	27	53	58	87
6	30	28	54	62	92
11	35	29	55	63	93
12	36	30	56	64	94
13	37	48	77	65	95
14	38	49	78	66	96
15	39	50	79	67	97
16	40	51	80	68	98
21	47	52	81	69	99
22	48	53	82	70	100

Screws covered by the following part numbers are inactive for new design and engineering. They shall be used for maintenance of existing equipment to replace the 5/16 inch size screws used in counterbored holes or other close applications.

Part Numbers
Inactive
MS35461
Dash Number
33
34
35
36
37
38

MS16995H

39
40
41
42
43
44

Custodians:
Army - AR
Navy - OS
Air Force - 82

Preparing activity:
DLA - IS
(Project 5305-2126)

Review activities:
Army - MI
Navy - MC, SH
Air Force - 11
NSA-NS