



PRINTED COPIES OF THIS DOCUMENT ARE FOR "REFERENCE" ONLY. CURRENT REVISIONS ARE AVAILABLE ONLINE.

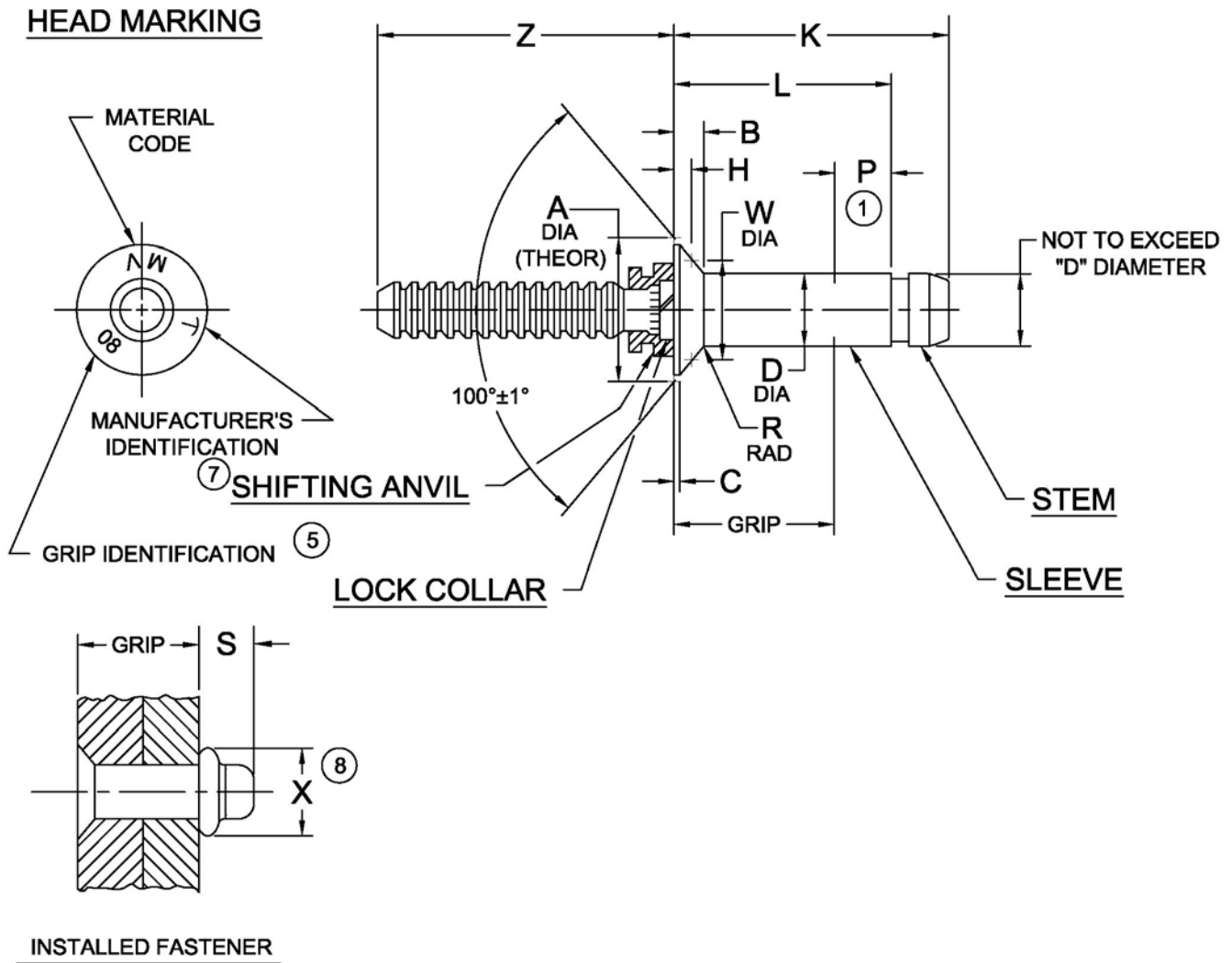

TABLE I

DIA. DASH NO.	D ±.001	A MAX REF	B MAX	C MAX	H	P MAX	R MAX	S MAX	W GAGE	X MIN ⑧	Z MIN	HOLE LIMITS	INSTALLED STRENGTH③	
													SINGLE SHEAR MINIMUM ④	TENSILE MINIMUM
-04	.128	.229	.042	.011	.0185 .0155	.190	.012	.200	.1841 .1839	.185	.812	.129/.132	1222	600
-05	.163	.333	.072	.011	.0206 .0171	.215	.012	.232	.2832 .2830	.235	.844	.164/.167	1980	900
-06	.198	.386	.080	.013	.0243 .0205	.250	.015	.292	.3272 .3270	.275	.875	.199/.202	2925	1400
-08	.259	.507	.105	.017	.0310 .0270	.305	.020	.361	.4320 .4318	.350	1.000	.260/.263	5005	2100
-10	.311	.634	.137	.020	.0367 .0325	.350	.025	.408	.5451 .5449	.410	1.218	.312/.315	7220	3100

NOTICE: ALL DIMENSIONS ARE IN INCHES AND APPLY AFTER FINISH AND BEFORE LUBRICATION UNLESS OTHERWISE SPECIFIED.

WARNING: FASTENERS MAY NOT PERFORM PROPERLY IF ALTERED FROM THE MANUFACTURER'S AS-SHIPED CONDITION OR INSTALLED IN CONDITIONS OTHER THAN SPECIFIED HEREIN.

PROCUREMENT SPECIFICATION: PS-CMB-7000	CHERRY® MAXIBOLT™ TITANIUM BLIND BOLT 100° FLUSH HEAD, TITANIUM STEM	SHEET 1 OF 4		PART NUMBER
NAS 523 CODE:		ISSUE	07-15-92	CR7770S
		REV.	AT 04 DEC 19	



TABLE II

GRIP DASH NO.	GRIP LIMITS			-04 DIA		-05 DIA	
	DESIGN GRIP RANGE ③		OVERLAP MAX ⑨	L REF	K MAX	L REF	K MAX
	MIN	MAX					
-02	.094	.157	.173	.321	.393	.336	.476
-03	.156	.220	.236	.383	.455	.398	.539
-04	.219	.282	.298	.446	.518	.460	.602
-05	.281	.345	.361	.508	.580	.523	.664
-06	.344	.407	.423	.570	.642	.585	.727
-07	.406	.470	.486	.633	.704	.648	.789
-08	.469	.532	.548	.695	.767	.710	.852
-09	.531	.595	.611	.758	.830	.773	.914
-10	.594	.657	.673	.820	.892	.835	.977
-11	.656	.720	.736	---	---	.898	1.039
-12	.719	.782	.798	---	---	.960	1.102
-13	.781	.845	.861	---	---	1.023	1.164
-14	.844	.907	.923	---	---	1.085	1.227
-15	.906	.970	.986	---	---	1.148	1.289
-16	.969	1.032	1.048	---	---	---	---

TABLE II (CONT'D)

GRIP DASH NO.	GRIP LIMITS			-06 DIA		-08 DIA		-10 DIA	
	DESIGN GRIP RANGE ③		OVERLAP MAX ⑨	L REF	K MAX	L REF	K MAX	L REF	K MAX
	MIN	MAX							
-02	.120	.157	.173	.365	.521	---	---	---	---
-03	.156	.220	.236	.427	.584	.479	.645	---	---
-04	.219	.282	.298	.490	.647	.541	.708	.624	.830
-05	.281	.345	.361	.552	.709	.604	.770	.686	.892
-06	.344	.407	.423	.615	.772	.666	.833	.749	.955
-07	.406	.470	.486	.677	.834	.729	.895	.811	1.017
-08	.469	.532	.548	.740	.897	.791	.958	.874	1.080
-09	.531	.595	.611	.802	.959	.854	1.020	.936	1.142
-10	.594	.657	.673	.865	1.022	.916	1.083	.999	1.205
-11	.656	.720	.736	.927	1.084	.979	1.145	1.061	1.267
-12	.719	.782	.798	.990	1.147	1.041	1.208	1.124	1.330
-13	.781	.845	.861	1.052	1.209	1.104	1.270	1.186	1.392
-14	.844	.907	.923	1.115	1.272	1.166	1.332	1.249	1.455
-15	.906	.970	.986	1.177	1.334	1.229	1.395	1.311	1.517
-16	.969	1.032	1.048	---	---	1.291	1.458	1.374	1.580

SHEET 2 OF 4			PART NUMBER	
ISSUE	07-15-92		CR7770S	
REV.	AT	04 DEC 19		



TABLE III

FINISH CODE	MATERIAL ②			FINISH		
	SLEEVE	STEM	LOCK COLLAR	SLEEVE	STEM ⑦	LOCK COLLAR
NONE	CP TITANIUM PER ASTM-B348 GR.1	38-6-44 TITANIUM PER AMS 4957	A-286 GRES AMS 5737	NONE	NONE	PASSIVATE AMS 2700
			INCONEL 600 AMS 5687			NONE
BE			A-286 GRES AMS 5737	ALUMINUM COAT PER NAS 4006 AND BMS 10-85		PASSIVATE AMS 2700
			INCONEL 600 AMS 5687			NONE
D			A-286 GRES AMS 5737 OR 316 GRES AMS 5690	IVD ALUM COAT PER MIL-DTL-83488 CLASS 3, TYPE2 PLUS CHROMATE TREATMENT PER SAE AMS-C-5541 CLASS 3		PASSIVATE AMS 2700
			INCONEL 600 AMS 5687			NONE
EE			A-286 GRES AMS 5737	ALUMINUM COAT PER NAS 4006		PASSIVATE AMS 2700
			INCONEL 600 AMS 5687			NONE
HK			A-286 GRES AMS 5737	HI-KOTE 1 PER HS294		PASSIVATE AMS 2700
			INCONEL 600 AMS 5687			NONE
W			A-286 GRES AMS 5737	BLUE ANODIZE PER ISO 8080		PASSIVATE AMS 2700
			INCONEL 600 AMS 5687			NONE
GD ⑩	A-286 GRES AMS 5737 OR	IVD ALUMINUM COAT PER MIL-DTL-83488 MIL-DTL-5541	PASSIVATE AMS 2700			
	INCONEL 600 AMS 5687		NONE			
GHK ⑩	A-286 GRES AMS 5737 OR	ALUMINUM COAT PER NAS4006, Class NC	PASSIVATE AMS 2700			
	INCONEL 600 AMS 5687		NONE			

SHEET 3 OF 4			PART NUMBER
ISSUE	07-15-92		CR7770S
REV.	AT	04 DEC 19	



NOTES:

- ① THIS LENGTH OF "D" DIA. MAY BE .002 UNDERSIZE.
- ② MATERIAL DESIGNATION REFERS TO CHEMICAL COMPOSITION ONLY.
- ③ MECHANICAL TESTING IN THE DESIGN GRIP RANGE ONLY. INSTALLATION TESTS ARE CONDUCTED IN THE OVERLAP GRIP.
- ④ SHEAR VALUES APPLY TO -04-03 MAX, -05-04 MAX, -06-05 MAX, -08-06 MAX, AND -10-07 MAX GRIPS AND LONGER.
- ⑤ SINGLE DIGIT HEAD MARKING IS PERMISSIBLE, AT MANUFACTURER'S OPTION, FOR GRIP DASH NUMBERS LESS THAN 10.
- 6. WHEN LUBRICATED, PARTS SHALL BE LUBRICATED PER AS5272 TYPE 1, MIL-L-87132, OR LOX (LIQUID OXYGEN) COMPATIBLE DRY FILM LUBRICANT.
- ⑦ FASTENERS ARE SUPPLIED WITH A SHIFTING ANVIL. SHIFTING ANVIL IS SOLID OR SPLIT, MANUFACTURER'S OPTION.
- ⑧ THE BLIND SIDE BULB DIAMETER "X" IS A "LOT QUALITY CONFORMANCE" REQUIREMENT AND IT IS SUBJECT TO AQL 4.0 (SEE PROCUREMENT SPEC). THIS IS NOT A DIMENSIONAL REQUIREMENT FOR THE END USERS AS THIS PRODUCT IS LARGELY INTENDED FOR "BLIND" APPLICATIONS.
- ⑨ OVERLAP IN DESIGN GRIP RANGES MAKES FASTENER WELL-SUITED FOR COMPOSITE STRUCTURES WITH LARGE GRIP TOLERANCES.
- ⑩ FINISH CODES WITH THE PREFIX 'G' INDICATE REACH COMPLIANT COATING.

EXAMPLE OF CHERRY PART NUMBER:

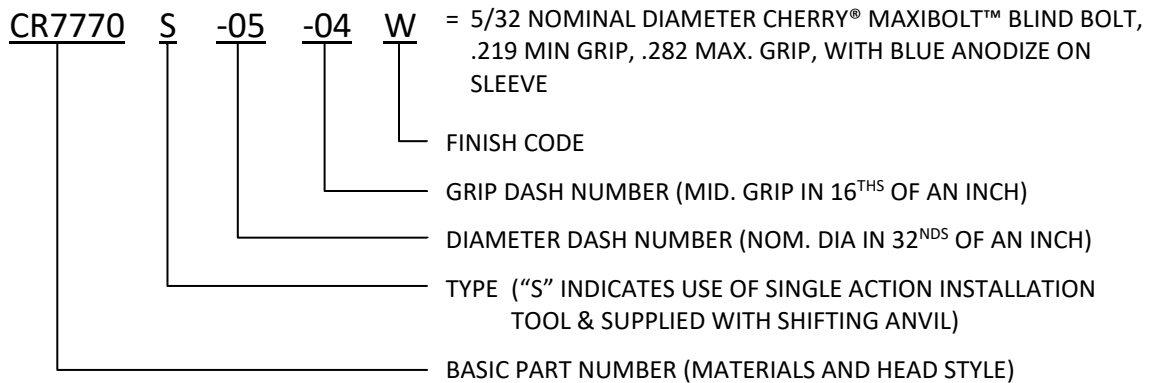

SHEET 4 OF 4		PART NUMBER
ISSUE	07-15-92	
REV.	AT	04 DEC 19
CR7770S		



STANDARDS PAGE REVISION LOG

REV LTR	DATE	DCR NUMBER	REVISION DESCRIPTION	COMP. BY
AT	04 DEC 19	19-0677	<ul style="list-style-type: none">• REWRITTEN IN WORD FROM AUTOCAD• SHEET 4 – UPDATED NOTE ⑧	AA