



PRINTED COPIES OF THIS DOCUMENT ARE FOR "REFERENCE" ONLY. CURRENT REVISIONS ARE AVAILABLE ONLINE.

HEAD MARKING ①

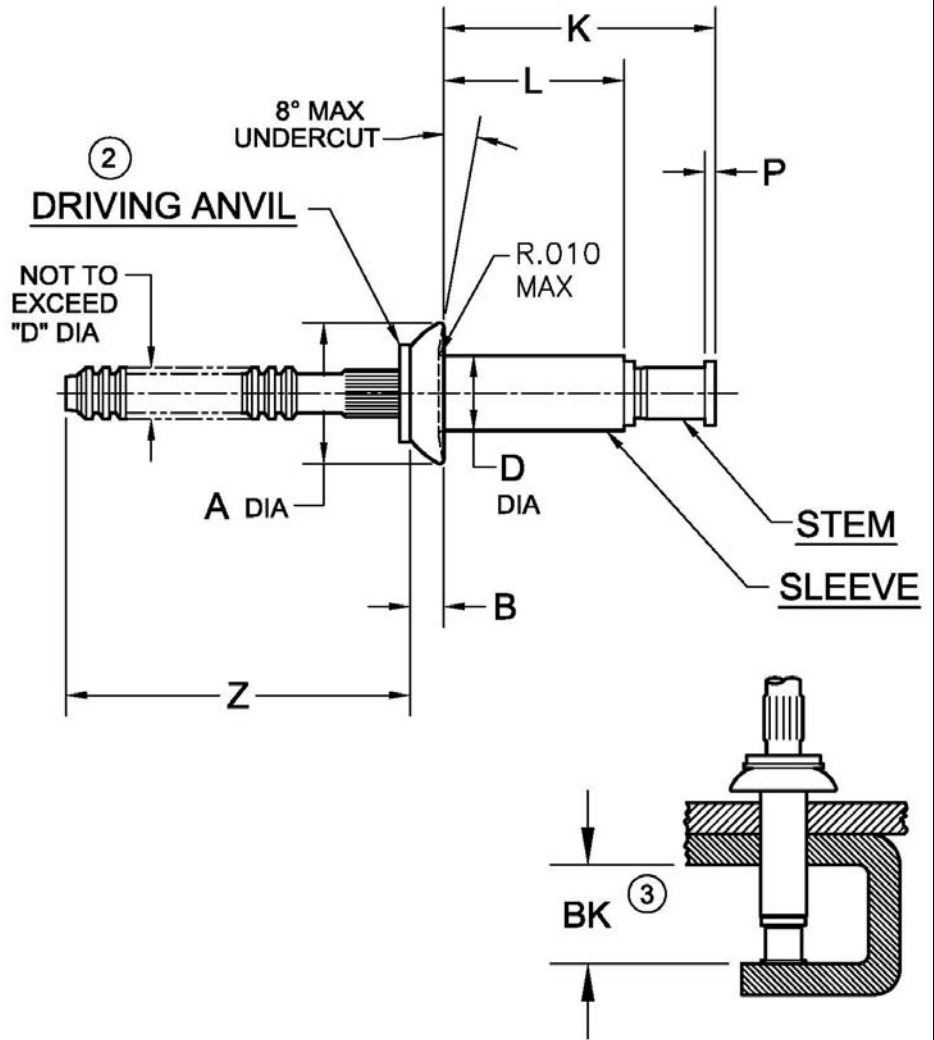
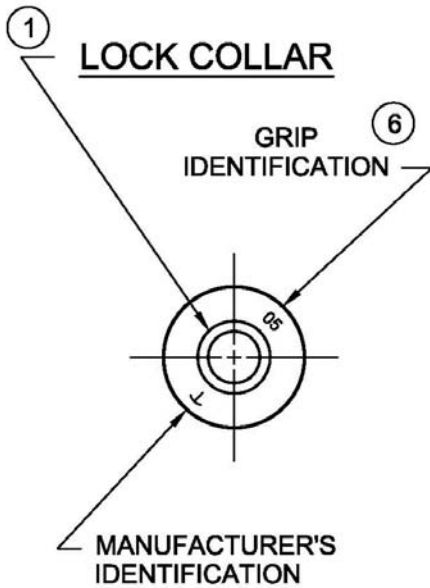

TABLE I

DIA. DASH NO.	A ±.010	B +.010 -.000	D +.003 -.001	P MIN	Z REF	BK MIN	HOLE LIMITS	
							MIN	MAX
-4	.250	.054	.126	.010	.87	.355	.129	.132
-5	.312	.067	.157	.015	.94	.370	.160	.164
-6	.375	.080	.189	.015	.94	.415	.192	.196
-8	.500	.107	.253	.015	.97	.485	.256	.261

NOTICE: ALL DIMENSIONS ARE IN INCHES AND APPLY AFTER FINISH AND BEFORE LUBRICATION UNLESS OTHERWISE SPECIFIED.

WARNING: FASTENERS MAY NOT PERFORM PROPERLY IF ALTERED FROM THE MANUFACTURER'S AS-SHIPPED CONDITION OR INSTALLED IN CONDITIONS OTHER THAN SPECIFIED HEREIN.

PROCUREMENT SPECIFICATION: PS-CMR-3000 NAS 523 CODE: SEE SHEET 2	CHERRYMAX® RIVET UNIVERSAL HEAD NOMINAL DIAMETER	SHEET 1 OF 3		PART NUMBER	
		ISSUE	6-24-92		CR3213
		REV.	AD	9-10-15	



TABLE II

FINISH CODE	NAS 523 CODE	MATERIAL ⑤			FINISH		
		SLEEVE	STEM	LOCK COLLAR	SLEEVE	STEM	LOCK COLLAR
---	ARN	5056 ALUMINUM PER QQ-A-430	8740 STEEL PER AMS6322	A-286 CRES PER AMS 5731 & AMS 5737	CHEM FILM PLAIN COLOR PER MIL-DTL-5541	CAD. PLATE PER AMS-QQ-P-416, TYPE II, CL2	PASSIVATE PER AMS 2700
A	---						
PR ⑧	ARN						
T ⑦	ARN				CHEM FILM PLAIN COLOR PER MIL-DTL-5541, CL 1A, TYPE II	ZINC PLATE PER AMS2417, TYPE II	
GZN ⑨	---						

TABLE III

GRIP DASH NO.	GRIP RANGE		-4 DIA		-5 DIA		-6 DIA		-8 DIA	
	MIN	MAX	L +.000 -.030	K MAX	L +.000 -.030	K MAX	L +.000 -.030	K MAX	L +.000 -.030	K MAX
-01	④	.062	.161	.38	.187	.41	.219	.47	---	---
-02	.063	.125	.224	.45	.230	.47	.262	.51	---	---
-03	.126	.187	.287	.51	.293	.53	.325	.57	.378	.65
-04	.188	.250	.349	.57	.355	.59	.387	.64	.440	.72
-05	.251	.312	.412	.63	.418	.65	.450	.70	.503	.78
-06	.313	.375	.474	.70	.480	.72	.512	.76	.565	.84
-07	.376	.437	.537	.76	.543	.77	.575	.82	.628	.90
-08	.438	.500	.599	.82	.605	.84	.637	.88	.890	.97
-09	.501	.562	.662	.88	.668	.90	.700	.95	.753	1.03
-10	.563	.625	---	---	.730	.96	.762	1.01	.815	1.09
-11	.626	.687	---	---	.793	1.02	.825	1.07	.878	1.15
-12	.688	.750	---	---	---	---	.887	1.13	.940	1.22
-13	.751	.812	---	---	---	---	.950	1.19	1.003	1.28
-14	.813	.875	---	---	---	---	---	---	1.065	1.34

SHEET 2 OF 3			PART NUMBER	
ISSUE	6-24-92		CR3213	
REV.	AD	9-10-15		



NOTES:

- ① HEAD MARKINGS AND LOCK COLLAR VISIBLE AFTER INSTALLATION.
- ② GOLD COLORED DRIVING ANVIL IDENTIFIES NOMINAL DIAMETER RIVETS.
- ③ MINIMUM BLIND SIDE CLEARANCE FOR SATISFACTORY INSTALLATION.
- ④ MINIMUM GRIIP FOR -4 DIA IS .025; FOR -5 IS .031; AND FOR -6 IS .037.
- ⑤ MATERIAL DESIGNATION REFERS TO CHEMICAL COMPOSITION ONLY.
- ⑥ SINGLE DIGIT HEAD MARKING IS PERMISSIBLE, AT MANUFACTURER'S OPTION, FOR GRIP DASH NUMBERS LESS THAN 10.
- ⑦ "T" CODE – PARTS ARE MANUFACTURED BARE; IIF LUBE IS REQUIRED, USE TRANSLUBE 20204 ONLY.
TRANSLUBE ("T" CODE) WILL BE UNAVAILABLE FOR PROCUREMENT AS OF 01-01-92.
- ⑧ PR" CODE – PARTS ARE MANUFACTURED BARE; IF LUBE IS REQUIRED, USE PAR 90 ONLY.
- ⑨ FINISH CODES WITH THE PREFIX "G" INDICATE REACH COMPLIANT COATING.

EXAMPLE OF CHERRY PART NUMBER:

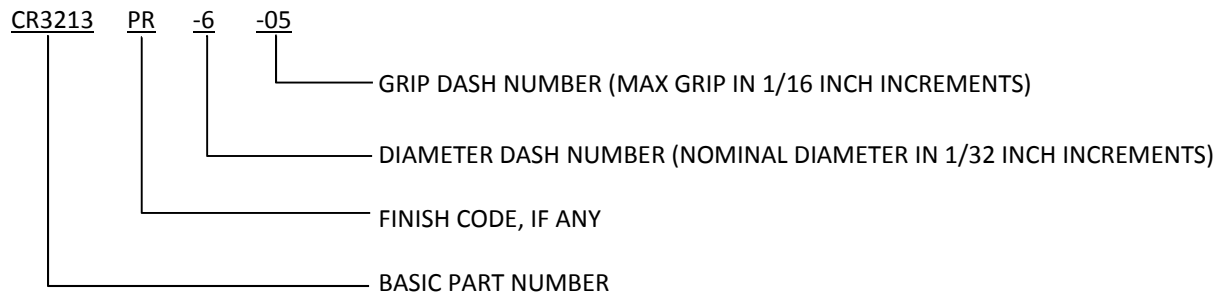

SHEET 3 OF 3		PART NUMBER
ISSUE	6-24-92	CR3213
REV.	AD 9-10-15	

STANDARDS PAGE REVISION LOG**CR3213**

REV LTR	DATE	DCR NUMBER	REVISION DESCRIPTION	COMP. BY
AD	9-10-15	15-0972	<ul style="list-style-type: none">• ADDED REACH COMPLIANT COATING GZN• ADDED NOTE 9• GENERAL CLEANUP AND STANDARDIZATION	MC