

INCH-POUND

AN924 Rev 14
15 February 2018
SUPERSEDING
AN924 Rev 13
14 April 20104

DETAIL SPECIFICATION SHEET

NUT, TUBE, BULKHEAD AND UNIVERSAL FITTING

Reinstated after 14 June 2012. Inactive for new design.
For new design, use SAE-AS5178.

This specification is approved for use by all Departments and
Agencies of the Department of Defense.

The requirements for acquiring the product described herein shall consist of this specification sheet and
SAE-AS4841.

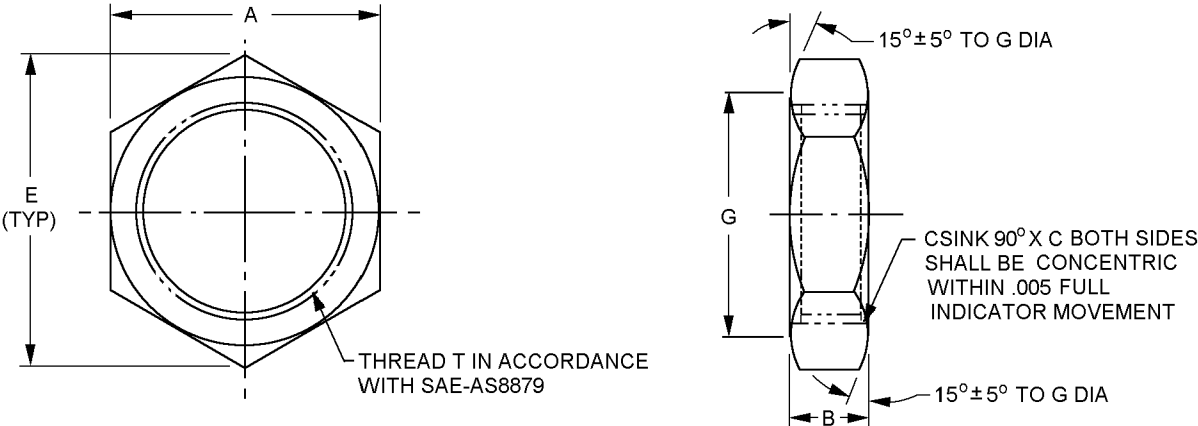

Inch mm
.005 0.13

See notes at end of figure.

FIGURE 1. Tube nut dimensions and configurations.



AN924 Rev 14

Dash number	Tubing OD	Thread T (Ref) SAE-AS8879	A (mm)		B (mm)	
-2	.125	.3125-24UNJF-3B	.563 (14.30)	+0.03 (0.08) -0.04 (0.10)	.219 (5.56)	
-3	.188	.3750-24UNJF-3B	.625 (15.88)		.219 (5.56)	
-4	.250	.4375-20UNJF-3B	.688 (17.48)		.250 (6.35)	
-5	.313	.5000-20UNJF-3B	.750 (19.05)		.250 (6.35)	
-6	.375	.5625-18UNJF-3B	.813 (20.65)		.266 (6.76)	
-8	.500	.7500-16UNJF-3B	1.000 (25.40)		.313 (7.95)	
-10	.628	.8750-14UNJF-3B	1.125 (28.58)		.359 (9.12)	
-12	.750	1.0625-12UNJ-3B	1.375 (34.93)		±0.16 (0.41) ±0.20 (0.51)	.406 (10.31)
-16	1.000	1.3125-12UNJ-3B	1.625 (41.28)			
-20	1.250	1.6250-12UNJ-3B	1.938 (49.23)			
-24	1.500	1.875-12UNJ-3B	2.188 (55.58)			
-28	1.750	2.250-12UNJ-3B	2.563 (65.10)			
-32	2.000	2.500-12UNJ-3B	2.813 (71.45)			
-40	2.500	3.000-12UNJ-3B	3.312 (84.12)			
-48	3.000	3.500-12UNJ-3B	3.812 (96.82)			

Dash number	C Dia.	E Min.	G ±0.10 (0.25) mm	H Max (see note 5) (mm)
-2	.313 (7.95)	.629 (15.98)	.500 (12.70)	.005 (0.13)
-3	.375 (9.53)	.699 (17.75)	.562 (14.27)	
-4	.438 (11.13)	.771 (19.58)	.625 (15.88)	
-5	.500 (12.70)	.842 (21.39)	.687 (17.45)	
-6	.563 (14.30)	.914 (23.22)	.750 (19.05)	
-8	.750 (19.05)	1.127 (28.63)	.937 (23.80)	
-10	.875(22.23)	1.270 (32.26)	1.052 (26.72)	
-12	1.063 (27.00)	1.555 (39.50)	1.274 (32.36)	.008 (0.20)
-16	1.313 (33.35)	1.827 (46.41)	1.524 (38.71)	
-20	1.625 (41.28)	2.184 (55.47)	1.838 (46.69)	
-24	1.875 (47.63)	2.465 (62.61)	2.093 (53.16)	
-28	2.250 (57.15)	2.892 (73.46)	2.468 (62.69)	
-32	2.500 (63.50)	3.178 (80.72)	2.718 (69.04)	
-40	3.000 (76.20)	3.747 (95.17)	3.218 (81.74)	
-48	3.500 (88.90)	4.318 (109.68)	3.718 (94.44)	

NOTES:

1. Dimensions are in inches.
2. Metric equivalents are given for information only.
3. Unless otherwise specified tolerances are ±0.016 inch (0.41 mm) angles ±0.5°.
4. Break sharp edges and remove all hanging burrs and slivers.
5. Squareness between thread and face of hex shall not exceed H when measured at diameter G, both sides.
6. Machined surfaces shall be finished to 125µin Ra, forged surfaces shall be 250µin Ra, unless otherwise specified on the figures. Surface finish shall be in accordance with ASME B46.1.
7. For design features purposes, this standard takes precedence over documents referenced herein.
8. Referenced documents shall be of the issue in effect on date of invitation for bid.

FIGURE 1. Tube nut dimensions and configurations - Continued.

REQUIREMENTS:

Dimensions and configuration shall be in accordance with figure 1.

Installation shall be in accordance with MS21344.

Materials shall be in accordance with SAE-AS4841, see table I for material and finish code.

Finish. Finishes shall be as specified in table I. All plating's shall be capable of meeting a minimum of 96 hours salt spray test in accordance with ASTM B117. The fittings shall show no evidence of red corrosion after 96 hours of salt spray. Fluid passages, other openings and internal threads shall not be subject to the plating thickness requirement and may have bare areas provided they are protected with a light film of oil.

TABLE I. Material and finish identification codes.

Material and finish code	Material	Plating finish
Blank	Steel	Cadmium plating in accordance with SAE-AS4841 <u>1/</u>
G	Steel	Zinc plating in accordance with ASTM B633; type V, Fe/Zn 8, <u>2/</u>
H	Steel	Zinc-aluminum in accordance with ASTM F1136/F1136M, grade 3, NC. <u>2/</u>
J	CRES type 304	In accordance with SAE-AS4841
K	CRES, type 316	In accordance with SAE-AS4841
L	Steel	Zinc-nickel in accordance with SAE-AMS2417, type 2, grade B <u>2/ 3/</u>
M	Nickel-copper alloy UNS N04400	No additional finish.
N	High-chromium nickel alloy UNS N06690	No additional finish.
P	Steel	Zinc phosphate finish in accordance MIL-DTL-16232 type Z, class1 <u>4/</u>
R	CRES, type 321	In accordance with SAE-AS4841
T	Titanium <u>4/</u>	Anodize in accordance with SAE-AMS2488 type 2.
TF		Fluoride phosphate in accordance with SAE-AMS2486. <u>5/</u>
W	Aluminum alloy 7075-T73	In accordance with SAE-AS4841
Z	Steel	Zinc plating in accordance with ASTM B695, type II, class 8. <u>4/</u>
ZN	Steel	Zinc may be any zinc plating from PIN codes G, L, and Z with a colored chromate coating. <u>4/</u>

1/ Embrittlement test need not be run. Cadmium shall not be used in oxygen or potable water systems. Cadmium is prohibited from use in NAVSEA owned shipboard systems.

2/ Hexavalent chromium free. Finish shall be RoHS compliant.

3/ The zinc-nickel alloy plate shall contain 12% to 16% nickel. The coating thickness shall be 315µ inches (8µm) minimum.

4/ Not for use in aircraft. Requires approval from the Program Office for all applications.

5/ A pretreatment, a modification of the fluoride treatment, or a post treatment shall be applied so the final color of the fittings shall be similar to SAE-AMS-STD-595 colors 36076 through 36293. Titanium shall not be used in oxygen or potable water systems.

AN924 Rev 14

Trivalent wrenchability. When the finish has been damaged due to poor wrenchability, the surface of the fluid passage bolt shall be touched up using the brush plating process below. The term "trivalent wrenchability" is used to evaluate the ability of the finish to withstand abrasion from an excessive amount of wrenching.

Brush plating of NAVAIR TCP shall be in accordance with MIL-DTL-81706, type 2, class 1A, material form 1 through 6, application method B. Example of a PIN: M817062A6B.

Part or Identifying Number (PIN): The PIN consists of the letters "AN" the specification sheet number, a dash number for pipe nut tube size, and a material and finish code letter. Unassigned PIN's shall not be used.

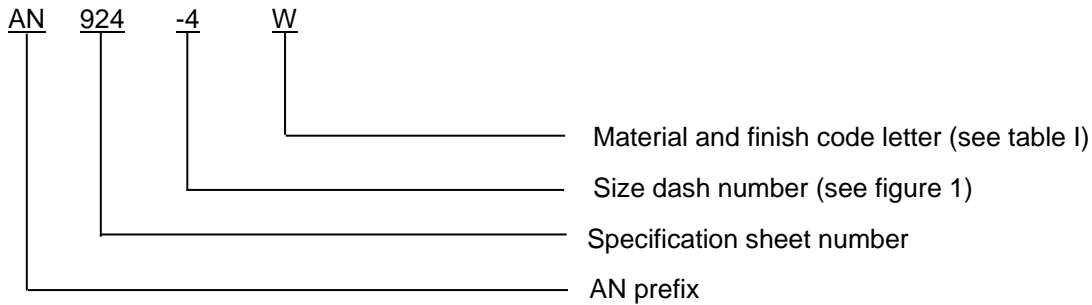

PIN example: AN924-4W indicates nut 1/4 inch tubing with aluminum alloy 7075-T73.

Marking: Part shall be impression stamped with AN, material/finish designator, and include the manufacturers CAGE, name, or trademark on the hex side only.

Cadmium is not recommended. To the users of this document, it is recommended that the use of carbon steel material with cadmium plating be used only when other materials and finishes specified in this document cannot meet performance requirements.

Cadmium is prohibited from use in NAVSEA owned shipboard systems in accordance with the requirements of T9070-AL-DPC-020/077-2.

Class I and II ozone depleting substances (ODS) shall not be used in AN914 or any referenced procedures.

Supersession data:

Due to stress corrosion cracking aluminum alloys 2014 and 2024 "D" designator has been replaced by aluminum alloy 7075 "W" designator example: AN924-4D use AN924-4W.

Metal cracking due to high temperatures CRES alloy 347 "S" designator has been replaced by CRES alloy 321 "R" designator. Example: AN9244S use AN924-4R.

AN924 and MS24400 CRES nuts of like size are physically interchangeable; however MS24400 nuts coded C cannot always replace AN924 nuts coded J or K and MS24400 nuts coded S cannot always replace AN924 nuts coded S.

Table II provides a detailed cross-reference of AN924 PINs and replacement SAE-AS5178 PINs. Users are cautioned to evaluate replacements for their particular application.

AN924 Rev 14

CAUTION: The superseding information is valid as of the date of this specification and may be superseded by subsequent revisions of the superseding document.

TABLE II. AN924 to SAE- AS5178 cross-reference data. 1/ 2/ 3/

AN PIN inactive for new design	Canceled AN PIN	Tube Size	Replacement AN PIN	AS PIN for new design
AN924-2	AN924-2D	.125	AN924-2W	AS5178-02-
		.125		AS5178W02
AN924-2J	AN924-2S	.125	AN924-2R	AS5178J02
AN924-2K		.125		AS5178K02
AN924-2R		.125		AS5178R02
		.125		AS5178R02
AN924-2T		.125		AS5178T02
AN924-2W		.125		AS5178W02
AN924-3	AN924-3D	.188	AN924-3W	AS5178-03-
		.188		AS5178W03
AN924-3J	AN924-3S	.188	AN924-3R	AS5178J03
AN924-3K		.188		AS5178K03
AN924-3R		.188		AS5178R03
		.188		AS5178R03
AN924-3T		.188		AS5178T03
AN924-3W		.188		AS5178W03
AN924-4	AN924-4D	.250	AN924-4W	AS5178-04-
		.250		AS5178W04
AN924-4J	AN924-4S	.250	AN924-4R	AS5178J04
AN924-4K		.250		AS5178K04
AN924-4R		.250		AS5178R04
		.250		AS5178R04
AN924-4T		.250		AS5178T04
AN924-4W		.250		AS5178W04
AN924-5	AN924-5D	.312	AN924-5W	AS5178-05-
		.312		AS5178W05
AN924-5J	AN924-5S	.312	AN924-5R	AS5178J05
AN924-5K		.312		AS5178K05
AN924-5R		.312		AS5178R05
		.312		AS5178R05
AN924-5T		.312		AS5178T05
AN924-5W		.312		AS5178W05
AN924-6	AN924-6D	.375	AN924-6W	AS5178-06-
		.375		AS5178W06
AN924-6J	AN924-6S	.375	AN924-6R	AS5178J06
AN924-6K		.375		AS5178K06
AN924-6R		.375		AS5178R06
		.375		AS5178R06
AN924-6T		.375		AS5178T06
AN924-6W		.375		AS5178W06

See notes at end of table.

AN924 Rev 14

TABLE II. AN924 to SAE- AS5178 cross-reference data - Continued. 1/ 2/ 3/

AN PIN inactive for new design	Canceled AN PIN	Tube Size	Replacement AN PIN	AS PIN for new design
AN924-8	AN924-8D	.500	AN924-8W	AS5178-08-
		.500		AS5178W08
AN924-8J	AN924-8S	.500	AN924-8R	AS5178J08
AN924-8K		.500		AS5178K08
AN924-8R		.500		AS5178R08
		.500		AS5178R08
AN924-8T		.500		AS5178T08
AN924-8W		.500		AS5178W08
AN924-10	AN924-10D	.625	AN924-10W	AS5178-10-
		.625		AS5178W10
AN924-10J	AN924-10S	.625	AN924-10R	AS5178J10
AN924-10K		.625		AS5178K10
AN924-10R		.625		AS5178R10
		.625		AS5178R10
AN924-10T		.625		AS5178T10
AN924-10W		.625		AS5178W10
AN924-12	AN924-12D	.750	AN924-12W	AS5178-12-
		.750		AS5178W12
AN924-12J	AN924-12S	.750	AN924-12R	AS5178J12
AN924-12K		.750		AS5178K12
AN924-12R		.750		AS5178R12
		.750		AS5178R12
AN924-12T		.750		AS5178T12
AN924-12W		.750		AS5178W12
AN924-16	AN924-16D	1.000	AN924-16W	AS5178-16-
		1.000		AS5178W16
AN924-16J	AN924-16S	1.000	AN924-16R	AS5178J16
AN924-16K		1.000		AS5178K16
AN924-16R		1.000		AS5178R16
		1.000		AS5178R16
AN924-16T		1.000		AS5178T16
AN924-16W		1.000		AS5178W16
AN924-20	AN924-20D	1.250	AN924-20W	AS5178-20-
		1.250		AS5178W20
AN924-20J	AN924-20S	1.250	AN924-20R	AS5178J20
AN924-20K		1.250		AS5178K20
AN924-20R		1.250		AS5178R20
		1.250		AS5178R20
AN924-20T		1.250		AS5178T20
AN924-20W		1.250		AS5178W20

See notes at end of table.

AN924 Rev 14

TABLE II. AN924 to SAE- AS5178 cross-reference data - Continued. 1/ 2/ 3/

AN PIN inactive for new design	Canceled AN PIN	Tube Size	Replacement AN PIN	AS PIN for new design
AN924-24	AN924-24D	1.500	AN924-24W	AS5178-24-
		1.500		AS5178W24
AN924-24J	AN924-24S	1.500	AN924-24R	AS5178J24
AN924-24K		1.500		AS5178K24
AN924-24R		1.500		AS5178R24
		1.500		AS5178R24
AN924-24T		1.500		AS5178T24
AN924-24W		1.500		AS5178W24
AN924-28	AN924-28D	1.750	AN924-28W	AS5178-28-
		1.750		AS5178W28
AN924-28J	AN924-28S	1.750	AN924-28R	AS5178J28
AN924-28K		1.750		AS5178K28
AN924-28R		1.750		AS5178R28
		1.750		AS5178R28
AN924-28T		1.750		AS5178T28
AN924-28W		1.750		AS5178W28
AN924-32	AN924-32D	2.000	AN924-32W	AS5178-32-
		2.000		AS5178W32
AN924-32J	AN924-32S	2.000	AN924-32R	AS5178J32
AN924-32K		2.000		AS5178K32
AN924-32R		2.000		AS5178R32
		2.000		AS5178R32
AN924-32T		2.000		AS5178T32
AN924-32W		2.000		AS5178W32
AN924-40	AN924-40D	2.500	AN924-40W	AS5178-40-
		2.500		AS5178W40
AN924-40J	AN924-40S	2.500	AN924-40R	AS5178J40
AN924-40K		2.500		AS5178K40
AN924-40R		2.500		AS5178R40
		2.500		AS5178R40
AN924-40T		2.500		AS5178T40
AN924-40W		2.500		AS5178W40
AN924-48	AN924-48D	3.000	AN924-48W	AS5178-48-
		3.000		AS5178W48
AN924-48J	AN924-48S	3.000	AN924-48R	AS5178J48
AN924-48K		3.000		AS5178K48
AN924-48R		3.000		AS5178R48
		3.000		AS5178R48
AN924-48T		3.000		AS5178T48
AN924-48W		3.000		AS5178W48

1/ For new design use material designator R and W.

2/ Hardness has to be specified in the contract or purchase order.

3/ SAE does not have plating finish designators for the following types:
G, H, L, M, N, P, TF, Z, and ZN.

Order of precedence. Unless otherwise noted herein or in the contract, in the event of a conflict between the text of this document and the references cited herein, the text of this document takes precedence. Nothing in this document, however, supersedes applicable laws and regulations unless a specific exemption has been obtained.

Referenced documents shall be of the issue in effect on date of invitations for bid.

Changes from previous issue. Marginal notations are not used in this revision to identify changes with respect to the previous issue, due to the extent of the changes.

Referenced documents. In addition to SAE-AS4841, this document references the following:

MIL-DTL-16232	SAE-AMS-STD-595/36099	SAE-AMS-STD-595/36280
MIL-DTL-81706	SAE-AMS-STD-595/36118	SAE-AMS-STD-595/36293
MS21344	SAE-AMS-STD-595/36134	SAE-AMS2417
ASME B46.1	SAE-AMS-STD-595/36152	SAE-AMS2486
ASTM B117	SAE-AMS-STD-595/36170	SAE-AMS2488
ASTM B633	SAE-AMS-STD-595/36173	SAE-AS5178
ASTM B695	SAE-AMS-STD-595/36176	SAE-AS8879
ASTM F1136/F1136M	SAE-AMS-STD-595/36231	T9070-AL-DPC-020/077-2
SAE-AMS-STD-595/36076	SAE-AMS-STD-595/36251	
SAE-AMS-STD-595/36081	SAE-AMS-STD-595/36270	

CONCLUDING MATERIAL

Custodians:

Army - AV
Navy - AS
Air Force - 99
DLA - CC

Preparing activity:
DLA - CC

(Project 4730-2018-019)

Review activities:

Navy - SA
Air Force - 71

NOTE: The activities listed above were interested in this document as of the date of this document. Since organizations and responsibilities can change, you should verify the currency of the information above using the ASSIST Online database at <https://assist.dla.mil>.