

INCH-POUND

AN842 Rev 13
3 October 2013
SUPERSEDING
AN842 Rev 12
7 June 2011

DETAIL SPECIFICATION SHEET

ELBOW - PIPE TO HOSE, 90°

Reinstated after 7 June 2011. Inactive for new design after 7 June 2011. For new design, use SAE-AS5185.

This specification is approved for use by all Departments and Agencies of the Department of Defense.

The requirements for acquiring the product described herein shall consist of this specification sheet and SAE-AS4843/2.

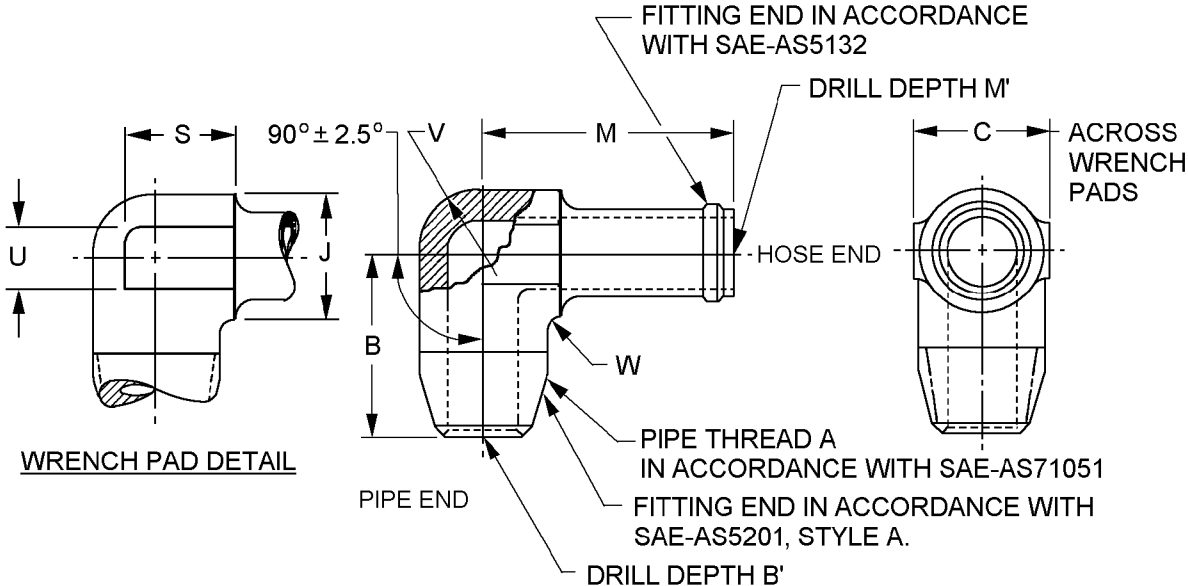

FIGURE 1. 90° elbow dimensions and configuration.

AN842 Rev 13

Dash number	Hose ID inches (mm)	A Pipe thread	B inches (mm) +.047 (1.19) -.000	B' +.047 (1.19) -.000 inches (mm)	C inches (mm)
4	.250 (6.35)	1/8-27 ANPT	.781 (19.84)	.781 (19.84)	.438 (11.13)
6	.375 (9.53)	1/4-18 ANPT	1.094 (27.77)	1.125 (28.58)	.625 (15.88)
8	.500 (12.70)	3/8-18 ANPT	1.188 (30.18)	1.250 (31.75)	.750 (19.05)
10	.625 (15.88)	1/2-14 ANPT	1.203 (30.56)	1.609 (40.87)	.938 (23.83)
12	.750 (19.05)	3/4-14 ANPT	1.594 (40.49)	1.719 (43.66)	1.125 (28.58)
16	1.000 (25.40)	3/4-14 ANPT	1.594 (40.49)	1.719 (43.66)	1.125 (28.58)
17	1.000 (25.40)	1-11.5 ANPT	1.953 (49.61)	2.078 (52.78)	1.375 (34.93)
20	1.250 (31.75)	1 1/4-11.5 ANPT	2.063 (52.40)	2.188 (55.58)	1.750 (44.45)
21	1.250 (31.75)	1-11.5 ANPT	2.063 (52.40)	2.188 (55.58)	1.375 (34.93)
24	1.500 (38.10)	1 1/2-11.5 ANPT	2.188 (55.58)	2.313 (58.75)	2.000 (50.80)
25	1.500 (38.10)	1 1/4-11.5 ANPT	2.031 (51.59)	2.297 (58.34)	1.750 (44.45)

Dash number	J dia. inches (mm)	M +.047 (1.19) -0.000 inches (mm)	M' +.047 (1.19) -0.000 inches (mm)	S approx inches (mm)	U approx inches (mm)
4	.438 (11.13)	1.718 (43.64)	1.718 (43.64)	.344 (8.74)	.313 (7.95)
6	.578 (14.68)	1.906 (48.41)	1.938 (49.23)	.500 (12.70)	.313 (7.95)
8	.719 (18.26)	1.984 (50.39)	2.047 (51.99)	.625 (15.88)	.438 (11.13)
10	.891 (22.63)	2.172 (55.17)	2.297 (58.34)	.750 (19.05)	.438 (11.13)
12	1.094 (27.79)	2.203(55.96)	2.328 (59.13)	.938 (23.83)	.500 (12.70)
16	1.094 (27.79)	2.203 (55.96)	2.328 (59.13)	.938 (23.83)	.500 (12.70)
17	1.375 (34.93)	2.344 (59.54)	2.469 (62.71)	1.125 (28.58)	.563 (14.30)
20	1.719 (43.66)	2.516 (63.91)	2.641 (67.08)	1.313 (33.35)	.563 (14.30)
21	1.375 (34.93)	2.344 (59.54)	2.469 (62.71)	1.125 (28.58)	.563 (14.30)
24	1.953 (49.61)	2.641 (67.08)	2.766 (70.26)	1.500 (38.10)	.625 (15.88)
25	1.719 (43.66)	2.641 (67.08)	2.766 (70.26)	1.500 (38.10)	.625 (15.88)

Dash number	V radius. inches (mm)	W radius inches (mm)
4	.219 (5.56)	.063 (1.60)
6	.297 (7.54)	.094 (2.39)
8	.359 (9.12)	.094 (2.39)
10	.438 (11.13)	.125 (3.18)
12	.547 (13.89)	.125 (3.18)
16	.547 (13.89)	.125 (3.18)
17	.688 (17.48)	.125 (3.18)
20	.859 (21.82)	.125 (3.18)
21	.688 (17.48)	.125 (3.18)
24	.969 (24.61)	.125 (3.18)
25	.859 (21.82)	.125 (3.18)

FIGURE 1. 90° elbow dimensions and configuration - Continued.

NOTES:

1. Dimensions are in inches.
2. Metric equivalents are given for information only.
3. Unless otherwise specified tolerances are ± 0.016 inch (0.41 mm).
4. Break sharp edges, and remove all hanging burrs and slivers
5. Machined surfaces shall be finished to 125 μ -in Ra, forged surfaces shall be 250 μ -in Ra, unless otherwise specified on the figures. Surface finish shall be in accordance with ASME B46.1.
6. For design features purposes, this standard takes precedence over documents referenced herein.
7. Referenced documents shall be of the issue in effect on date of invitation for bid.

FIGURE 1. 90° elbow dimensions and configuration - Continued.

REQUIREMENTS:

The elbow dimensions and configuration shall be in accordance with figure 1.

Materials and finishes shall be in accordance with SAE-AS4843/2, see table I for material and finish code.

TABLE I. Material and finish code letters.

Material and finish code	Material	Protective chemical finish <u>3/ 4/</u>
Blank <u>1/</u>	Copper alloy, type 377 forging in accordance with ASTM B124/B124M or half hard forging or bar in accordance with ASTM B138/B138M or bar in accordance with SAE-AMS4614	No finish
BC <u>1/</u>	Copper alloy, type 377 forging in accordance with ASTM B124/B124M or half hard forging or bar in accordance with ASTM B138/B138M or bar in accordance with SAE-AMS4614	Cadmium in accordance with SAE-AMS-QQ-P-416, type II, class 3
D <u>2/</u>	Type 2014-T6 aluminum alloy forging in accordance with SAE-AMS-QQ-A-367 or SAE-AMS4133, or type 2024-T6 aluminum alloy bar in accordance with SAE-AMS-QQ-A-225/6, or type 2024-T851 aluminum alloy bar in accordance with SAE-AMS-QQ-A-225/6 or SAE-AMS4339	Anodize in accordance with SAE-AMS2472 or MIL-A-8625, type II, class 2, dye blue, duplex seal in accordance with procurement specification.
DV <u>2/</u>	Type 2014-T6 aluminum alloy forging in accordance with SAE-AMS-QQ-A-367 or SAE-AMS4133, or type 2024-T6 aluminum alloy bar in accordance with SAE-AMS-QQ-A-225/6, or type 2024-T851 aluminum alloy bar in accordance with SAE-AMS-QQ-A-225/6 or SAE-AMS4339	High purity aluminum in accordance with MIL-DTL-83488, class 3, type II with maximum coating thickness of .0005 inch. Glass bead peen pressure shall be 25 psi (1.72 bar) maximum.

See notes at end of table.

TABLE I. Material and finish code - Continued.

Material and finish code	Material	Protective chemical finish <u>3/</u> <u>4/</u>
J	Type 304 corrosion resistant steel forging or bar in accordance with SAE-AMS-QQ-S-763 or SAE-AMS5639	Passivate in accordance with SAE-AMS2700, type VI or VII
K	Type 316 corrosion resistant steel forging or bar in accordance with SAE-AMS-QQ-S-763 or SAE-AMS5648	Passivate in accordance with SAE-AMS2700, type VI or VII
R	Type 321 corrosion resistant steel forging or bar in accordance with SAE-AMS-QQ-S-763 or SAE-AMS5645.	Passivate in accordance with SAE-AMS2700, type VI or VII
W <u>2/</u>	Type 7075-T73 aluminum alloy forging in accordance with SAE-AMS-QQ-A-367 or SAE-AMS4141, or type 7075-T73 aluminum alloy bar in accordance with SAE-AMS-QQ-A-225/9, in accordance with type 7075-T7351 Aluminum alloy bar in accordance with SAE-AMS4124.	Anodize in accordance with SAE-AMS2472 or MIL-A-8625, type II, class 2, dye brown similar to color 10080 in accordance with FED-STD-595, duplex seal in accordance with procurement specification.
WV <u>2/</u>	Type 7075-T73 aluminum alloy forging in accordance with SAE-AMS-QQ-A-367 or SAE-AMS4141, or type 7075-T73 aluminum alloy bar in accordance with SAE-AMS-QQ-A-225/9, in accordance with type 7075-T7351 Aluminum alloy bar in accordance with SAE-AMS4124.	High purity aluminum in accordance with MIL-DTL-83488, class 3, type II with maximum coating thickness of .0005 inch. Glass bead peen pressure shall be 25 psi (1.72 bar) maximum
T <u>3/</u>	Titanium	Anodize in accordance with SAE-AMS2488, type 2

1/ Material code was dash on previous revisions, changed to agree with SAE-ARP1590.

2/ Aluminum code D is inactivated, use code W.

3/ Titanium and cadmium shall not be used in oxygen systems.

4/ Cadmium shall not be used in potable water systems.

AN842 Rev 13

Parts for use on oxygen systems shall be identified in the PIN as code "A" and shall be furnished cleaned, packaged, and labeled in accordance with SAE-AS611 to a process approved by the user.

Users are cautioned that the 90° pipe elbow should be evaluated to their cleanliness requirements before installing in any equipment. Only qualified technical personnel with knowledge for the selection of cleaning methods for oxygen rich environments should make the determination as to what cleanliness level is acceptable for their application.

PIN: The PIN consists of the prefix "AN" the specification sheet number, a dash number for hose and pipe thread size, material code letter, finish code, and oxygen code. Unassigned PIN's shall not be used.

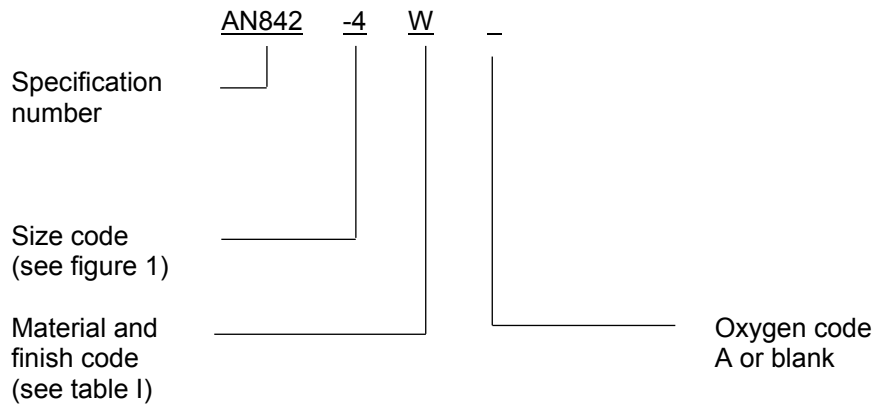

PIN examples:

AN842-8W indicates a 90° elbow .500 inch (12.70 mm) hose to .375 inch (9.53 mm) pipe, aluminum alloy 7075-T73.

A842-8WV indicates a 90° elbow .500 inch (12.70 mm) hose to .375 inch (9.53 mm) pipe, aluminum alloy 7075-T73 finish with high purity aluminum.

AN842-12WA indicates a 90° elbow .750 inch (19.05 mm) hose to .750 inch (19.05 mm) pipe, aluminum alloy 7075-T73 for use in oxygen systems.

Guidance on use of alternative parts with less hazardous or non-hazardous materials. This specification provides for a number of alternative plating materials via the PIN. Users should select the PIN with the least hazardous material that meets the form, fit, and function requirements of their application.

Marking: Part shall be permanently marked with the AN PIN, and include the manufacturers CAGE, name, or trademark.

Table II provides a detailed cross-reference of AN842 PINs and replacement SAE-AS5185 PINs. Users are cautioned to evaluate replacements for their particular application.

CAUTION: The superseding information is valid as of the date of this specification and may be superseded by subsequent revisions of the superseding document.

AN842 Rev 13

TABLE II. Cross-reference data. 1/

AN PIN Inactive part	Hose Size	Pipe Size	AS PIN <u>2/</u> Active part
AN842-4	0.250	0.125	AS5185B0402
AN842-4D	0.250	0.125	AS5185W0402
AN842-4R	0.250	0.125	AS5185R0402
AN842-4S	0.250	0.125	AS5185R0402
AN842-4W	0.250	0.125	AS5185W0402
AN842-6	0.375	0.250	AS5185B0604
AN842-6D	0.375	0.250	AS5185W0604
AN842-6R	0.375	0.250	AS5185R0604
AN842-6S	0.375	0.250	AS5185R0604
AN842-6W	0.375	0.250	AS5185W0604
AN842-8	0.500	0.375	AS5185B0806
AN842-8D	0.500	0.375	AS5185W0806
AN842-8R	0.500	0.375	AS5185R0806
AN842-8S	0.500	0.375	AS5185R0806
AN842-8W	0.500	0.375	AS5185W0806
AN842-10	0.625	0.500	AS5185B1008
AN842-10D	0.625	0.500	AS5185W1008
AN842-10R	0.625	0.500	AS5185R1008
AN842-10S	0.625	0.500	AS5185R1008
AN842-10W	0.625	0.500	AS5185W1008
AN842-12	0.750	0.750	AS5185B1212
AN842-12D	0.750	0.750	AS5185W1212
AN842-12R	0.750	0.750	AS5185R1212
AN842-12S	0.750	0.750	AS5185R1212
AN842-12W	0.750	0.750	AS5185W1212
AN842-16	1.000	0.750	AS5185B1612
AN842-16D	1.000	0.750	AS5185W1612
AN842-16R	1.000	0.750	AS5185R1612
AN842-16S	1.000	0.750	AS5185R1612
AN842-16W	1.000	0.750	AS5185W1612
AN842-17	1.000	1.000	AS5185B1616
AN842-17D	1.000	1.000	AS5185W1616
AN842-17R	1.000	1.000	AS5185R1616
AN842-17S	1.000	1.000	AS5185R1616
AN842-17W	1.000	1.000	AS5185W1616

See notes at end of table.

TABLE II. Cross-reference data - Continued. 1/

AN PIN Inactive part	Hose Size	Pipe Size	AS PIN <u>2/</u> Active part
AN842-20	1.250	1.250	AS5185B2020
AN842-20D	1.250	1.250	AS5185W2020
AN842-20R	1.250	1.250	AS5185R2020
AN842-20S	1.250	1.250	AS5185R2020
AN842-20W	1.250	1.250	AS5185W2020
AN842-21	1.250	1.000	AS5185B2016
AN842-21D	1.250	1.000	AS5185W2016
AN842-21R	1.250	1.000	AS5185R2016
AN842-21S	1.250	1.000	AS5185R2016
AN842-21W	1.250	1.000	AS5185W2016
AN842-24	1.500	1.500	AS5185B2424
AN842-24D	1.500	1.500	AS5185W2424
AN842-24R	1.500	1.500	AS5185R2424
AN842-24S	1.500	1.500	AS5185R2424
AN842-24W	1.500	1.500	AS5185W2424
AN842-25	1.500	1.250	AS5185B2420
AN842-25D	1.500	1.250	AS5185W2420
AN842-25R	1.500	1.250	AS5185R2420
AN842-25S	1.500	1.250	AS5185R2420
AN842-25W	1.500	1.250	AS5185W2420

1/ For new design use material designator R and W.

2/ SAE "B" designator for copper alloy parts can be either no finish or cadmium plate.

Order of precedence. Unless otherwise noted herein or in the contract, in the event of a conflict between the text of this document and the references cited herein, the text of this document takes precedence. Nothing in this document, however, supersedes applicable laws and regulations unless a specific exemption has been obtained.

Referenced documents shall be of the issue in effect on date of invitations for bid.

Changes from previous issues. Marginal notations are not used in this revision to identify changes with respect to the previous issue due to the extent of the changes.

Referenced documents. In addition to SAE-AS4843/2, this document references the following:

FED-STD-595/10080	SAE-AMS-QQ-P-416	SAE-AMS4339
MIL-A-8625	SAE-AMS-QQ-S-763	SAE-AMS5645
MIL-DTL-83488	SAE-AMS2472	SAE-AMS5648
ASTM B124/B124M	SAE-AMS2488	SAE-AMS5639
ASTM B138/B138M	SAE-AMS2700	SAE-ARP1590
ASME B46.1	SAE-AMS4124	SAE-AS611
SAE-AMS-QQ-A-225/6	SAE-AMS4133	SAE-AS5132
SAE-AMS-QQ-A-225/9	SAE-AMS4141	SAE-AS5185
SAE-AMS-QQ-A-367	SAE-AMS4614	SAE-AS5201
		SAE-AS71051

CONCLUDING MATERIAL

Custodians:

Army - AV
Navy - AS
Air Force - 99
DLA - CC

Preparing activity:
DLA - CC

(Project 4730-2013-041)

Review activity:

Air Force - 71

NOTE: The activities listed above were interested in this document as of the date of this document. Since organizations and responsibilities can change, you should verify the currency of the information above using the ASSIST Online database at <https://assist.dla.mil>.