

USER ACTIVITIES

REVIEWER ACTIVITIES

This military standard is approved for use by all Departments and Agencies of the Department of Defense. Selection for all new engineering and design applications and for repetitive use shall be made from this document.

FED. SUP CLASS
4730

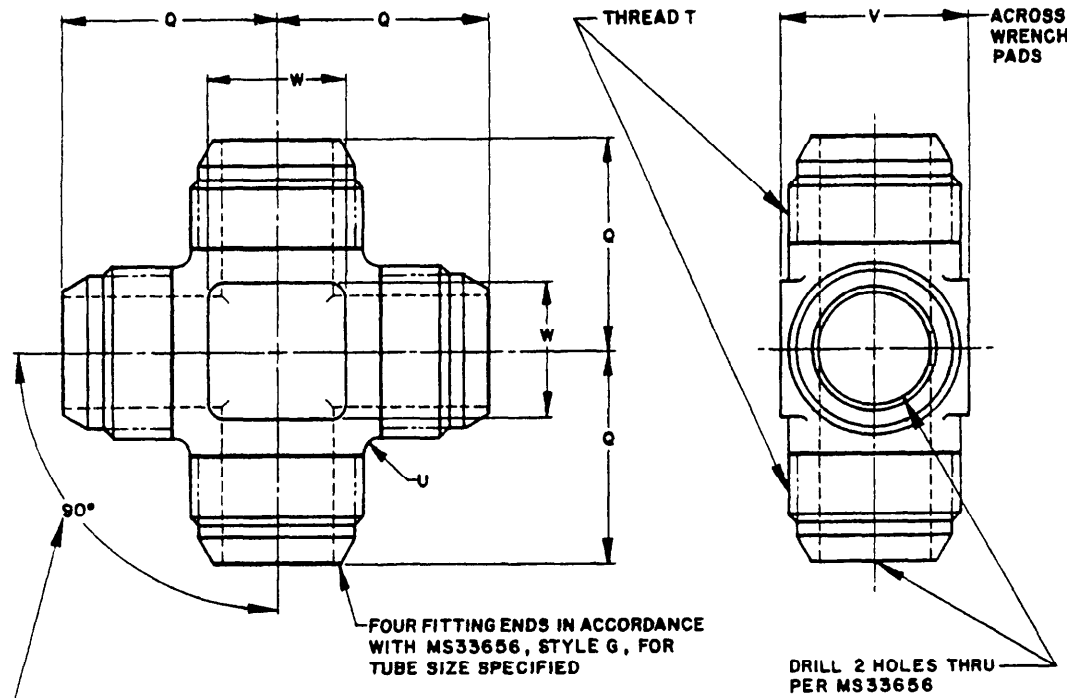

TOLERANCE UP TO AND INCLUDING -6 SIZE $\pm 2-1/2^\circ$
ABOVE -6 SIZE $\pm 1-1/2^\circ$

MATERIAL: STEEL; BARS, SHAPES OR FORGINGS.
TITANIUM ALLOY; BARS, SHAPES OR FORGINGS.
ALUMINUM ALLOY; BARS, SHAPES OR FORGINGS.
CORROSION RESISTANT STEEL; BARS, SHAPES OR FORGINGS. SEE PROCUREMENT SPECIFICATION

FINISH: SEE PROCUREMENT SPECIFICATION.

NO CODE LETTER IN PART NUMBER FOR STEEL.
ADD D AFTER DASH NUMBER FOR ALUMINUM ALLOY (EXCEPT 7075-T73).
ADD J AFTER DASH NUMBER FOR CORROSION RESISTANT STEEL, TYPE 304.
ADD K AFTER DASH NUMBER FOR CORROSION RESISTANT STEEL, TYPE 316.
ADD S AFTER DASH NUMBER FOR CORROSION RESISTANT STEEL, TYPE 347.
ADD T AFTER DASH NUMBER FOR TITANIUM.
ADD W AFTER DASH NUMBER FOR 7075-T73.

EXAMPLE OF PART NUMBER:
AN827-4 - CROSS, 1/4 TUBING, STEEL.
AN827-4D - CROSS, 1/4 TUBING, ALUMINUM ALLOY (EXCEPT 7075-T73).
AN827-4J - CROSS, 1/4 TUBING, CORROSION RESISTANT STEEL, TYPE 304.
AN827-4K - CROSS, 1/4 TUBING, CORROSION RESISTANT STEEL, TYPE 316.
AN827-4S - CROSS, 1/4 TUBING, CORROSION RESISTANT STEEL, TYPE 347.
AN827-4T - CROSS, 1/4 TUBING, TITANIUM.
AN827-4W - CROSS, 1/4 TUBING, 7075-T73.

BREAK ALL SHARP EDGES AND REMOVE ALL HANGING BURRS AND SLIVERS WHICH MIGHT BECOME DISLODGED UNDER USAGE.

TITANIUM NOT TO BE USED IN OXYGEN SYSTEMS.

DIMENSIONS IN INCHES. UNLESS OTHERWISE SPECIFIED, TOLERANCES: FRACTIONS $\pm 1/64$, DECIMALS $\pm .005$, ANGLES $\pm 1/2$.

Reinstated as of 16 April 1982

ORIGINAL STANDARD REVISED

P. A. AIR FORCE-99 ARMY-AV NAVY-AS	INTERNATIONAL INTEREST	AIRFORCE-NAVY AERONAUTICAL STANDARD	AN827
		CROSS-FLARED TUBE	
PROCUREMENT SPECIFICATION MIL-F-5509	SUPERSEDES:	SHEET 1 OF 2	

USER ACTIVITIES:

REVIEWER ACTIVITIES:

This military standard is approved for use by all Departments and Agencies of the Department of Defense. Selection for all new engineering and design applications and for repetitive use shall be made from this document.

DASH NO.	TUBING OD	6 THREAD T (REF)	^Q +3/64 -0	U RAD	V	W APPROX
2	1/8	5/16-24UNJF-3A	47/64	1/16	5/16	5/16
3	3/16	3/8 -24UNJF-3A	51/64		3/8	3/8
4	1/4	7/16-20UNJF-3A	55/64		7/16	
5	5/16	1/2 -20UNJF-3A	59/64		1/2	15/32
6	3/8	9/16-18UNJF-3A	1- 1/32	3/32	9/16	1/2
8	1/2	3/4 -16UNJF-3A	1- 7/32		3/4	11/16
10	5/8	7/8 -14UNJF_3A	1-27/64	1/8	7/8	25/32
12	3/4	1-1/16-12UNJF-3A	1- 5/8		1-1/16	29/32
16	1	1-5/16-12UNJF-3A	1-25/32		1-5/16	1- 3/32
20	1-1/4	1-5/8 -12UNJF-3A	2- 1/32		1-5/8	1- 5/16
24	1-1/2	1-7/8 -12UNJF-3A	2-19/64		1-7/8	1- 1/2
28	1-3/4	2-1/4 -12UNJF-3A	2-25/32	3/16	2-1/4	1-25/32
32	2	2-1/2 -12UNJF-3A	3- 1/32	1/4	2-9/16	2-1/32

APPROVED 13 DEC 40 REVISED 6 FOR CHANGES SEE PAGES 1 & 2. 16 April 1982

6 ENTIRE STANDARD REVISE		AIR FORCE-NAVY AERONAUTICAL STANDARD		AN827
AIR FORCE-99 Other Code ARMY-AV NAVY-AS		CROSS - FLARED TUBE		
PROCUREMENT SPECIFICATION MIL-F-8509	SUPERSEDES:			SHEET 2 OF 2