

USER ACTIVITIES
ARMY-HE, AV
NAVY-AS
DLA-CS

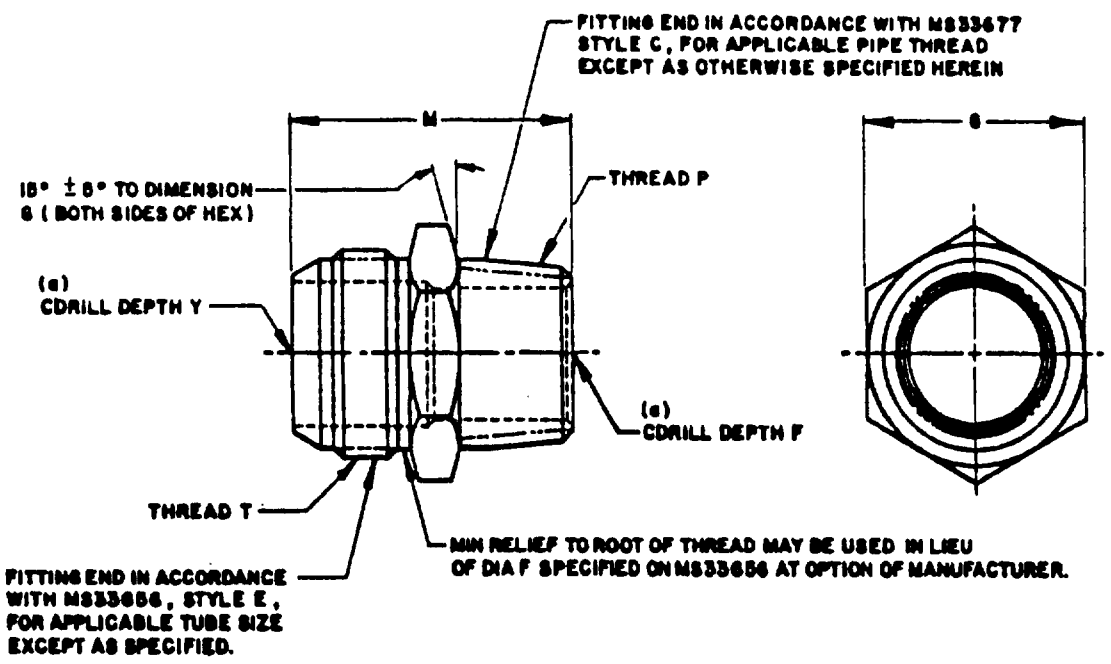

DISTRIBUTION STATEMENT A. APPROVED FOR PUBLIC RELEASE; DISTRIBUTION IS UNLIMITED.
 REVIEWER ACTIVITIES:
 ARMY-HE, AV
 NAVY-AS
 DLA-CS
 This military standard is approved for use by all Departments and Agencies of the Department of Defense.
 Selection for all new engineering and design applications and for repetitive use shall be made from this document.
 AMSC N/A

(a) DRILL IS ONLY FROM THE END OF LARGER DRILL. THE LARGER COUNTERDRILL IS NOT MANDATORY. AT THE OPTION OF THE MANUFACTURER THE SMALLER DIA MAY BE DRILLED THROUGH THE FITTING FROM END TO END.

MATERIAL: STEEL, ALUMINUM ALLOY, COPPER ALLOY, CORROSION RESISTANT STEEL (CRS): BARS.
SEE PROCUREMENT SPECIFICATION

FINISH: SEE PROCUREMENT SPECIFICATION.

NO CODE LETTER IN PART NUMBER FOR CARBON STEEL.
 ADD B AFTER DASH NUMBER FOR COPPER ALLOY.
 ADD D AFTER DASH NUMBER FOR ALUMINUM ALLOY (EXCEPT 7075-T73).
 ADD J AFTER DASH NUMBER FOR CRS, TYPE 304.
 ADD K AFTER DASH NUMBER FOR CRS, TYPE 316.
 ADD S AFTER DASH NUMBER FOR CRS, TYPE 347.
 ADD W AFTER DASH NUMBER FOR 7075-T73 ALUMINUM ALLOY.

EXAMPLES OF PART NUMBERS:
 AN816-4 - ADAPTER, 1/4 TUBING OD TO 1/8 PIPE, CARBON STEEL.
 AN816-4B - ADAPTER, 1/4 TUBING OD TO 1/8 PIPE, COPPER ALLOY.
 AN816-4D - ADAPTER, 1/4 TUBING OD TO 1/8 PIPE, ALUMINUM ALLOY (EXCEPT 7075-T73).
 AN816-4J - ADAPTER, 1/2 TUBING OD TO 3/8 PIPE, CRS, TYPE 304.
 AN816-4K - ADAPTER, 1/2 TUBING OD TO 3/8 PIPE, CRS, TYPE 316.
 AN816-4S - ADAPTER, 1/2 TUBING OD TO 3/8 PIPE, CRS, TYPE 347.
 AN816-4W - ADAPTER, 1/2 TUBING OD TO 3/8 PIPE, 7075-T73 ALUMINUM ALLOY.

BREAK ALL SHARP EDGES AND REMOVE ALL HANGING BURRS AND SLIVERS.
 DIMENSIONS IN INCHES. UNLESS OTHERWISE SPECIFIED, TOLERANCES: FRACTIONS ±1/64, DECIMALS ±.005, ANGLES ±1/2°.

CERTAIN PROVISIONS (SCREW THREADS, HEXAGON, AND UNDERCUT DIMENSIONS) OF THIS STANDARD ARE THE SUBJECT OF INTERNATIONAL STANDARDIZATION AGREEMENT ABC AIR STD 17/15. WHEN REVISION OR CANCELLATION OF THIS STANDARD IS PROPOSED, THE DEPARTMENTAL CUSTODIANS WILL INFORM THEIR RESPECTIVE DEPARTMENTAL STANDARDIZATION OFFICES SO THAT APPROPRIATE ACTION MAY BE TAKEN RESPECTING THE INTERNATIONAL AGREEMENT CONCERNED.

INACTIVE FOR DESIGN AFTER 9 JANUARY 1964, EXCEPT FOR USE ON OXYGEN SYSTEMS AND GROUND SERVICE EQUIPMENT. SEE MIL-STD-882 FOR STATUS CRITERIA.

NOTES:
 REFERENCED GOVERNMENT (OR NONGOVERNMENT) DOCUMENTS OF THE ISSUE LISTED IN THAT ISSUE OF THE DEPARTMENT OF DEFENSE INDEX OF SPECIFICATIONS AND STANDARDS (DODISS) SPECIFIED IN THE SOLICITATION FORM A PART OF THIS STANDARD TO THE EXTENT SPECIFIED HEREIN.
 FOR DESIGN FEATURE PURPOSES, THIS STANDARD TAKES PRECEDENCE OVER ACQUISITION DOCUMENTS REFERENCED HEREIN.

(13) ENTIRE STANDARD REVISED

APPROVED 13 DEC 40
 REVISED (13) 15 APRIL 1988

P. A. AIR FORCE - 82 Other Code	INTERNATIONAL INTEREST	AIR FORCE-NAVY AERONAUTICAL STANDARD		AN816
	AIR FORCE - 89	ADAPTER, STRAIGHT, PIPE TO TUBE		
PROCUREMENT SPECIFICATION MIL - P - 8809		SUPERSEDED:		SHEET 1 OF 2

DASH NO.	TUBING OD	TMD P ANPT ± .016	THREAD T (REF) ± .016	F ± .016	G		H ± .016	Y ± .016		
-2	1/8	.125	.3125-24UNJF-3A	.469	.438	+.003 -.004	1.016			
-3	3/16		.3750-24UNJF-3A				.500	1.047		
-4	1/4		.4375-20UNJF-3A				.688	.563	1.109	
-4-4		.250			1.375					
-5	5/16	.125	.5000-20UNJF-3A	.688	.562	± .004	1.141	.625		
-5-4		.250							1.375	
-6-2	3/8	.125	.5625-18UNJF-3A	.688	.625	± .004	1.187	.687		
-6		.250							1.375	
-6-6		.375					.688	.750	1.406	
-6-8		.500					.875	.875	1.625	
-7	1/2	.250	.7500-16UNJF-3A	.688	.613	± .004	1.500	.844		
-8		.375								
-10	5/8	.500	.8750-14UNJF-3A	.906	.938	± .005	1.828			
-10-12		.750							1.844	
-12-8	3/4	.500	1.0625-12UNJ-3A	.906	1.125	± .005	1.953	1.062		
-12		.750							2.187	
-12-16		1.000					1.062		2.031	1.031
-16-12	1	.750	1.3125-12UNJ-3A	1.125	1.375	± .016	2.219			
-16		1.000							2.359	
-20	1-1/4	1.250	1.6250-12UNJ-3A	1.187	1.688	± .016	2.328	1.250		
-21		1.000							2.547	1.344
-25	1-1/2	1.250	1.8750-12UNJ-3A		2.000	± .020	2.828	1.437		
-28	1-3/4	1.500	2.2500-12UNJ-3A		2.375		3.109			
-32	2	2.000	2.5000-12UNJ-3A	1.437	2.625					

This standard is approved for use by all Departments and Agencies of the Department of Defense. Subsequent to this approval, changes in this standard may be made without notice.

APPROVED 13 DEC 40 REVISED 13 FOR CHANGES SEE PAGES 1 & 2.

13 ENTIRE STANDARD REVISED

P. A.
AIR FORCE - 82
Other Cost
AIR FORCE - 99

INTERNATIONAL INTEREST

AIR FORCE - NAVY AERONAUTICAL STANDARD

ADAPTER, STRAIGHT, PIPE TO TUBE

AN 816

PROCUREMENT SPECIFICATION
MIL - F - 5509

SUPERSEDES:

SHEET 2 OF 2