

USER SYMBOLS

REVIEWER SYMBOLS

Reviewer/user information is current as of the date of this document. For future coordination of changes to this document, draft circulation should be based on the information in the current DOOISS.

This military standard is approved for use by all Departments & Agencies of the Department of Defense. Selection for all new engineering and design applications and for repetitive use shall be made from this document.

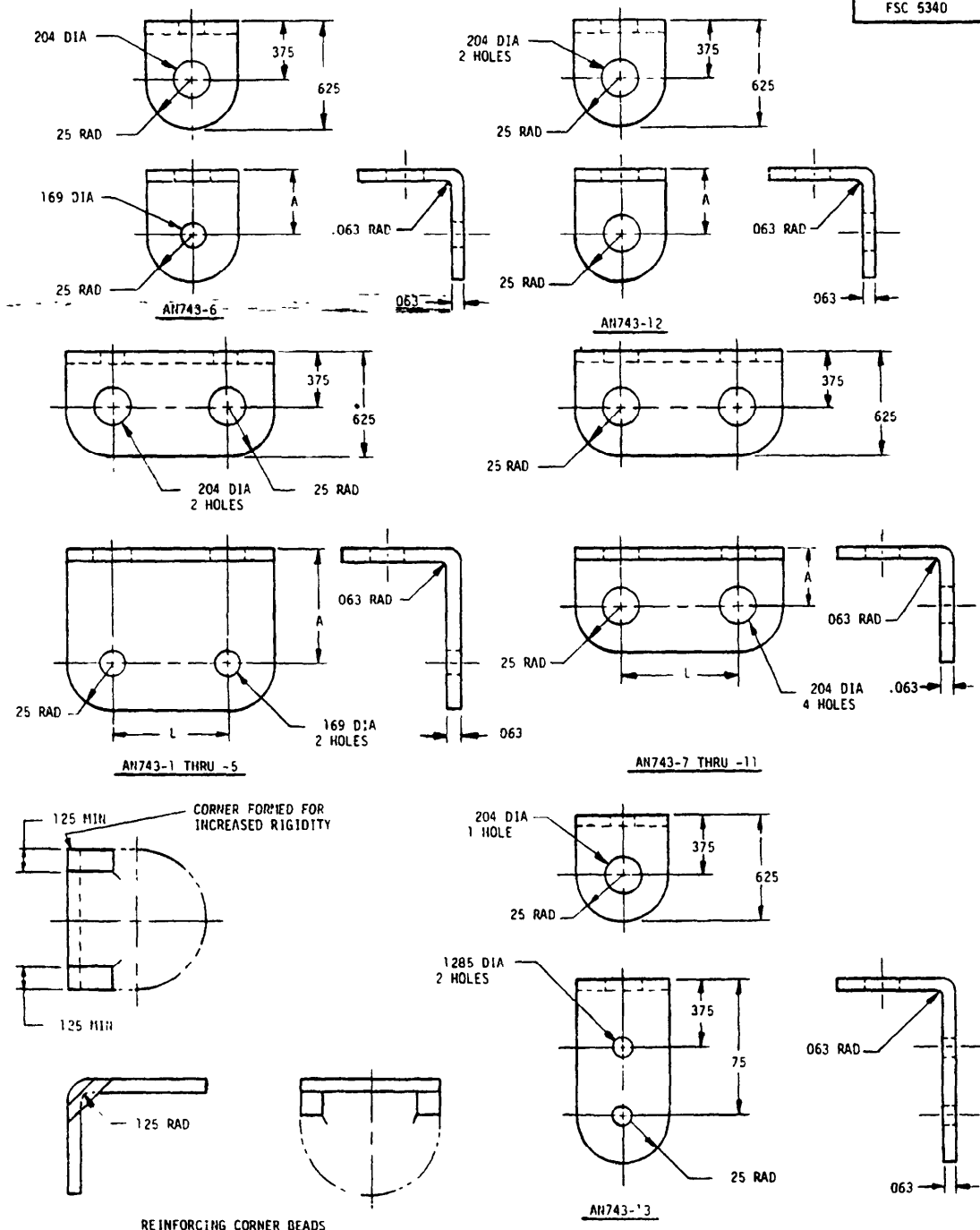

- ⑥ CANCELLED AFTER 15 SEPT 1981 NO SUPERSEDING STANDARD
- ⑦ REINSTATED AFTER 30 AUG 1982
- ⑦ DENOTES CHANGE

APPROVED 21 JUN 44 REVISED 7 16 AUG 82

PROCUREMENT SPECIFICATION
NONE

AIR FORCE-NAVY AERONAUTICAL STANDARD

BRACKET, SUPPORT CLAMP

AN743

SHEET 1 OF 2

USER SYMBOLS

REVIEWER SYMBOLS

AN PART NO.	A	L ±.005	RECOMMENDED FOR USE WITH AN742	
			PLATE CLAMP	CUSHION CLAMP
AN743-1	.59	.305	- 2 TO - 8 INCL	- 4C TO -10C INCL
AN743-2	.59	.450	- 9 TO -16 INCL	-11C TO -18C INCL
(a) AN743-3	.59	1.180	-17 TO -32 INCL	-19C TO -34C INCL
AN743-4	.59	1.680	-34 TO -48 INCL	-36C TO -50C INCL
AN743-5	.59	2.180	-52 TO -64 INCL	-54C TO -86C INCL
(b) AN743-6	.44		FOR ONE HOLE MOUNTING	
AN743-7	.38	.500	- 8 TO -11 INCL	-10C TO -13C INCL
AN743-8		.625	-12 TO -15 INCL	-14C TO -17C INCL
AN743-9		.750	-16 TO -24 INCL	-18C TO -26C INCL
AN743-10		1.000	-25 TO -40 INCL	-27C TO -42C INCL
AN743-11		1.500	FOR LONG BASE MOUNTING	
AN743-12	.44		FOR ONE HOLE MOUNTING	
AN743-13			FOR ONE HOLE MOUNTING	

- (a) PART NUMBERS AN743-1, -2, -3, -4, AND -5, INACTIVE FOR DESIGN AFTER 31 JULY 1945
PART NUMBERS AN743-7, -8, -9, -10, AND -11 REPLACE AND ARE INTERCHANGEABLE WITH
AN743-1, -2, -3, -4, AND -5, RESPECTIVELY.
- (b) PART NUMBER AN743-6 INACTIVE FOR DESIGN AFTER 21 APRIL 1950 PART NUMBER
AN743-12 REPLACES AND IS INTERCHANGEABLE WITH AN743-6

MATERIAL ALUMINUM ALLOY 2024, SPECIFICATION QQ-A-362, CONDITION T3 OR EXTRUDED SHAPES.
AND10134-0602 AND AND10134-1001 SPECIFICATION QQ-A-267, TEMPER T4
STEEL; SPECIFICATION MIL-S-18729, CONDITION H.
CORROSION RESISTANT STEEL, SPECIFICATION MIL-S-5059, COMPOSITION 302, ANNEALED

HEAT TREAT SPECIFICATION MIL-R-6088, 50,000 PSI TENSILE STRENGTH MINIMUM.

FINISH ALUMINUM ALLOY ANODIZE, SPECIFICATION MIL-A-8625, TYPE I OR TYPE II, WHEN SPECIFIED.
STEEL, CADMIUM PLATE, SPECIFICATION QQ-P-416, TYPE II, CLASS 3
CORROSION RESISTANT STEEL, NONE

ADD C BEFORE DASH NUMBER FOR CORROSION RESISTANT STEEL BRACKET

ADD P BEFORE DASH NUMBER FOR STEEL BRACKET, CADMIUM PLATED

ADD B IN PLACE OF DASH TO DESIGNATE INCORPORATION OF REINFORCING CORNER BEADS

ADD Z IN PLACE OF DASH FOR ANODIZED ALUMINUM ALLOY.

EXAMPLES OF PART NUMBERS: AN743-7 = BRACKET, SUPPORT CLAMP, ALUMINUM ALLOY
AN743-C7 = BRACKET, SUPPORT CLAMP, CORROSION RESISTANT STEEL
AN743-P7 = BRACKET, SUPPORT CLAMP, STEEL, CADMIUM PLATED.
AN743BP7 = BRACKET, SUPPORT CLAMP, STEEL, CADMIUM PLATED, INCORPORATING
REINFORCING CORNER BEADS

ALUMINUM ALLOY PARTS, CODED R, WILL HAVE THICKNESS REDUCED TO .050

STEEL PARTS CODED R WILL HAVE THICKNESS REDUCED TO .040.

REMOVE ALL BURRS AND SHARP EDGES.

DIMENSIONS IN INCHES: UNLESS OTHERWISE SPECIFIED, TOLERANCES: THREE PLACE DECIMALS
± .010, TWO PLACE DECIMALS ± .02

Review/User information is current as of the date of this document.
For future coordination of changes to this document, draft circulation
should be based on the information in the current DODISS.

This voluntary standard is approved for use by all Departments
& Agencies of the Department of Defense. Selection for all new
engineering and design applications and for repetitive use shall
be made from this document.

APPROVED 21 JUN 44 REVISED 7 FOR CHANGES SEE SHEETS 1 & 2

PROCUREMENT
SPECIFICATION

NONE

AIR FORCE-NAVY AERONAUTICAL STANDARD

BRACKET, SUPPORT CLAMP

AN743

SHEET 2 OF 2