

NOTICE: When Government drawings, specifications or other data are used for any purpose other than in connection with a definitely related Government procurement operation, the United States Government thereby incurs no responsibility, nor any obligation whatsoever; and the fact that the Government may have furnished, furnished, or in any way supplied the said drawings, specifications, or other data is not to be regarded by implication or otherwise as in any manner licensing the holder or any other person or corporation, or conveying any rights or permission to manufacture, use, or sell any patented invention that may in any way be related thereto.

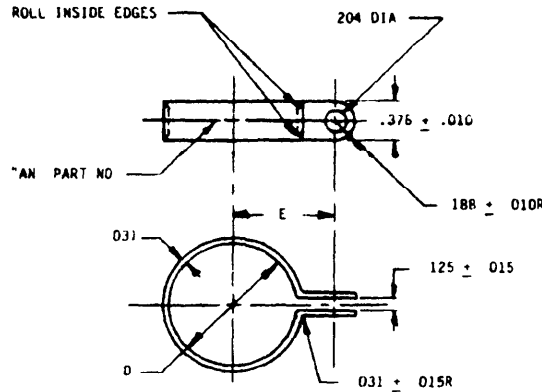

DASH NUMBERS	DIMENSIONS		LBS PER 100 PCS (APPROX)	
	'D' DIA ± .005	'E' ± .015	STEEL AND CRES	ALUM ALLOY
2	.125	.313	24	.08
3	.188	.344	31	11
4	.250	.375	37	13
5	.313	.406	44	15
6	.375	.469	.52	18
7	.438	.500	.59	.20
8	.500	.531	.65	.22
9	.563	.563	.72	.25
10	.625	.594	.78	.27
11	.688	.625	.85	.29
12	.750	.656	.91	.31
13	.813	.688	.98	.34
14	.875	.719	1.04	.36
15	.938	.750	1.10	.38
16	1.000	.813	1.19	.41
17	1.063	.844	1.25	.43
18	1.125	.875	1.32	.46
19	1.188	.906	1.38	.48
20	1.250	.938	1.45	.50
21	1.313	.969	1.51	.52
22	1.375	1.000	1.57	.54
23	1.438	1.031	1.64	.57
24	1.500	1.063	1.71	.59
25	1.563	1.094	1.77	.61
26	1.625	1.125	1.84	.63
27	1.688	1.156	1.90	.66
28	1.750	1.188	1.97	.68
30	1.875	1.250	2.09	.72
31	1.938	1.281	2.16	.75
32	2.000	1.313	2.22	.77
34	2.125	1.375	2.35	.81
35	2.188	1.406	2.42	.83
36	2.250	1.438	2.48	.86
38	2.375	1.500	2.61	.90
40	2.500	1.563	2.74	.95
43	2.688	1.656	2.93	1.01
44	2.750	1.688	2.99	1.03
48	3.000	1.813	3.25	1.12
52	3.250	1.938	3.51	1.21
56	3.500	2.063	3.77	1.30
64	4.000	2.313	4.29	1.48
72	4.500	2.563	4.81	1.65
80	5.000	2.813	5.33	1.84
88	5.500	3.063	5.84	2.02
96	6.000	3.313	6.36	2.19

(S) MATERIALS

- (-) = 1010 STEEL, TEMPER 4 PER ASTM A109-85
FINISH - CADMIUM PLATING PER QQ-P-416 TYPE II, CLASS 2
- (D) = ALUMINUM ALLOY PER QQ-A-250/5
FINISH - HEAT TREAT PER MIL-H-6088 TO T42 CONDITION
- (DC) = ALUMINUM ALLOY PER QQ-A-250/5
FINISH - HEAT TREAT PER MIL-H-6088 TO T42 CONDITION
CHEMICAL FILM PER MIL-C-5541, CLASS 3, COLOR GOLD
- (C) = 302 CRES STEEL PER MIL-S-5059, ANNEALED OR 321 CRES STEEL PER AMS 5510, ANNEALED
FINISH - CLEANED AND DESCALED IN ACCORDANCE WITH "ASTM A-380" AND PASSIVATED PER "QQ-P-35"

(S) NOTE ALUMINUM ALLOY CLAMPS MUST BE FORMED WITHIN ONE HOUR OF HEAT TREATMENT

(S) EXAMPLES OF PART NUMBER

- AN735-2 = STEEL CLAMP, 125 INSIDE DIA
- AN735D2 = ALUMINUM ALLOY CLAMP, .125 INSIDE DIA
- AN735DC2 = ALUMINUM ALLOY CLAMP WITH CHEMICAL FILM, .125 INSIDE DIA
- AN735C2 = CRES STEEL CLAMP, 125 INSIDE DIA

(S) CLAMPS SHALL CHECK TO DIMENSIONS WITH ENDS HELD IN POSITION SHOWN. CLAMPS SHALL BE DELIVERED WITH ENDS OPEN A MINIMUM OF THREE FOURTHS (3/4) OF THE INSIDE DIAMETER AND SHALL BE FLAT WITHIN .005 THROUGH THE CLAMP WIDTH. BANDS SHALL HAVE ALL BURRS, SHARP EDGES AND SCALE REMOVED.

DIMENSIONS IN INCHES UNLESS OTHERWISE SPECIFIED, TOLERANCES ± .005

(S) DEMOTES CHANGES

REPLACEMENT DRAWING APPROVED FOR PUBLIC RELEASE. DISTRIBUTION IS UNLIMITED.

NOTE: This drawing was approved by joint action of the Air Force and Navy Departments as the Air Force-Navy standard for this product. This drawing supersedes all antecedent standard drawings for the same product and shall become effective for the procurement of aeronautical supplies, or for use in new design not later than 6 months after the latest date of approval shown.

MSC: N/A

P.A. NAVY - AS	AIR FORCE-11
CUSTODIANS	
ARMY - AY	AIR FORCE - 99
USERS.	
DIA - IS	

AIR FORCE-NAVY AERONAUTICAL STANDARD

CLAMP, LOOP TYPE BONDING

AN735

PROCUREMENT SPEC NONE

SUPERSEDES NAF DWG 1051 AND ARMY CORPS DWG 735.

SHEET 1 OF 1

PREVIOUS EDITIONS OF THIS FORM ARE OBSOLETE.

PROJECT NO 5340-1736

APPROVED 20 MARCH 1944 REVISED (S) 12 FEB 87

NOTICE
OF VALIDATION

1 INCH-PCOUNT

AN735 REV 5
NOTICE 1
28 May 1993

MILITARY STANDARD
CLAMP, LOOP TYPE BONDING

AN735 Revision 5, dated 12 February 1987, has been reviewed and determined to be valid for use in acquisition.

Custodian:
Navy - AS
AF - 99

Preparing Activity:
Navy - AS

Review Activity:
Army - MI
DLA - IS

AMSC N/A

5340

DISTRIBUTION STATEMENT A. Approved for public release, distribution is unlimited