

REVISION HISTORY			
REV	DATE	BY	DESCRIPTION
C	10APR2019	CMS/JW	PRN: P2019-0933

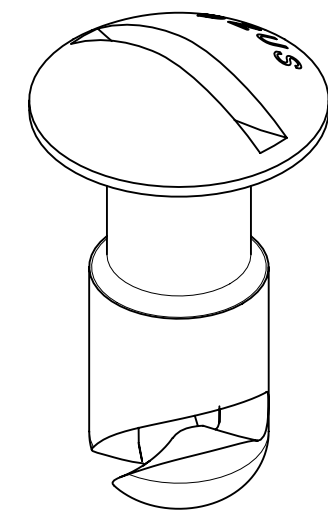
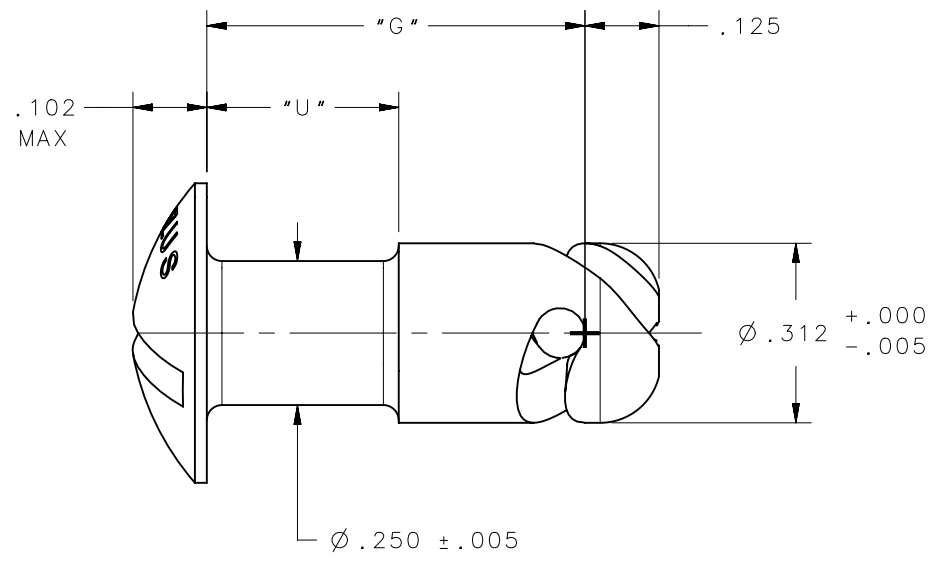
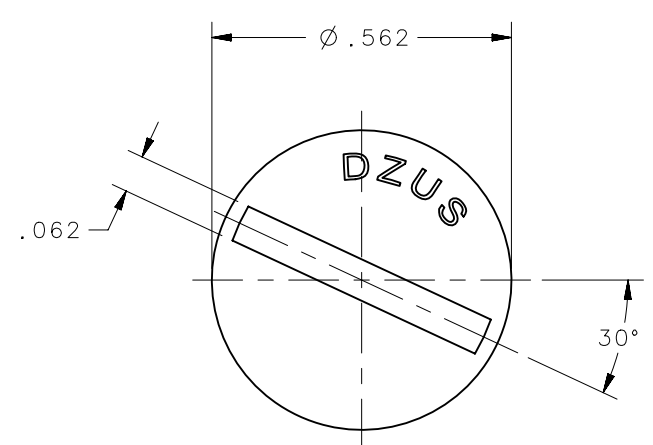

SCALE 5:1

121J-530-Z3CT	D4-AJ5-30ZCTNA	0.300	0.125
121J-530-Z5Y	D4-AJ5-30Z5YNA	0.300	0.125
121J-535-Z3C	D4-AJ5-35ZBCNA	0.350	0.125
121J-535-Z3CT	D4-AJ5-35ZCTNA	0.350	0.125
121J-540-Z3C	D4-AJ5-40ZBCNA	0.400	0.190
121J-540-Z3CT	D4-AJ5-40ZCTNA	0.400	0.190
121J-545-C3C	D4-AJ5-45CBCNA	0.450	0.190
121J-545-Z3C	D4-AJ5-45ZBCNA	0.450	0.190
121J-545-Z3CT	D4-AJ5-45ZCTNA	0.450	0.190
121J-550-Z3C	D4-AJ5-50ZBCNA	0.500	0.250
121J-550-Z3CT	D4-AJ5-50ZCTNA	0.500	0.250
121J-555-Z3C	D4-AJ5-55ZBCNA	0.550	0.275
121J-555-Z3CT	D4-AJ5-55ZCTNA	0.550	0.275
121J-560-Z3C	D4-AJ5-60ZBCNA	0.600	0.300
121J-560-Z3CT	D4-AJ5-60ZCTNA	0.600	0.300
121J-565-Z3CT	D4-AJ5-65ZCTNA	0.650	0.350
121J-570-Z3C	D4-AJ5-70ZBCNA	0.700	0.400
121J-570-Z3CT	D4-AJ5-70ZCTNA	0.700	0.400
121J-580-Z3C	D4-AJ5-80ZBCNA	0.800	0.500
121J-580-Z3CT	D4-AJ5-80ZCTNA	0.800	0.500
121J-5120-Z3C	D4-AJ5-120ZBCNA	1.200	0.700
121J-530-SS	D4-AJ5-30SSNA	0.300	0.125
121J-535-SS	D4-AJ5-35SSNA	0.350	0.125
121J-540-SS	D4-AJ5-40SSNA	0.400	0.190
121J-545-SS	D4-AJ5-45SSNA	0.450	0.190
121J-550-SS	D4-AJ5-50SSNA	0.500	0.250
121J-550-SS-PAS	D4-AJ5-50SSPSNA	0.500	0.250
121J-560-SS-PAS	D4-AJ5-60SSPSNA	0.600	0.300
121J-570-SS	D4-AJ5-70SSNA	0.700	0.400
121J-580-SS	D4-AJ5-80SSNA	0.800	0.500
121J-590-SS	D4-AJ5-90SSNA	0.900	0.600
121J-5100-SS	D4-AJ5-100SSNA	1.000	0.700
121J-5120-SS	D4-AJ5-120SSNA	1.200	0.700
DFCI PART NO.	SOUTHCO PART NO.	DIM "G"	DIM "U"

SEE NOTE A
SEE NOTE C
SEE NOTE B
MATERIAL
FINISH

NOTES:

A. AISI 8620 STEEL, HEAT TREATED TO ROCKWELL C27-33.

B. 304 STAINLESS STEEL.

C. REFER TO J-D5-0-3 FOR FINISH INFORMATION AND SPECIFICATIONS.

THIRD ANGLE PROJECTION		
INCHES [MM]		
TOLERANCES UNLESS OTHERWISE NOTED	DESCRIPTION	OVAL HEAD STUD
ALL DIMENSIONS WITHOUT TOLERANCES ARE FOR REFERENCE ONLY	SIZE	B
	SYSTEM	NX
	DWG NO.	J-D4-AJ5NA
PER ASME Y14.5M-1994	DRAWN BY	CMS/NJF
	DATE	25SEP2015
	SCALE	5:1
	SHEET	1 OF 1

PROPRIETARY ITEM
EXCEPT FOR USES EXPRESSLY GRANTED IN WRITING, INFORMATION DISCLOSED HEREON IS CONFIDENTIAL AND ALL RIGHTS, PATENT AND OTHERWISE, ARE RESERVED BY SOUTHCO, INC.